

SESSION - 1

GATE 2014: General Instructions during Examination

1. Total duration of the GATE examination is **180** minutes.
2. The clock will be set at the server. The countdown timer at the top right corner of screen will display the remaining time available for you to complete the examination. When the timer reaches zero, the examination will end by itself. You need not terminate the examination or submit your paper.
3. Any useful data required for your paper can be viewed by clicking on the **Useful Common Data** button that appears on the screen.
4. Use the scribble pad provided to you for any rough work. Submit the scribble pad at the end of the examination.
5. You are allowed to use a non-programmable type calculator, however, sharing of calculators is not allowed.
6. The Question Palette displayed on the right side of screen will show the status of each question using one of the following symbols:

 You have not visited the question yet.

 You have not answered the question.

 You have answered the question.

 You have NOT answered the question, but have marked the question for review.

 You have answered the question, but marked it for review.

The **Marked for Review** status for a question simply indicates that you would like to look at that question again. *If a question is answered, but marked for review, then the answer will be considered for evaluation unless the status is modified by the candidate.*

Navigating to a Question :

7. To answer a question, do the following:
 - a. Click on the question number in the Question Palette to go to that question directly.
 - b. Select an answer for a multiple choice type question by clicking on the bubble placed before the 4 choices, namely A, B, C and D. Use the virtual numeric keypad to enter a number as answer for a numerical type question.
 - c. Click on **Save & Next** to save your answer for the current question and then go to the next question.
 - d. Click on **Mark for Review & Next** to save your answer for the current question and also mark it for review, and then go to the next question.

Caution: Note that your answer for the current question will not be saved, if you navigate to another question directly by clicking on a question number without saving the answer to the previous question.

You can view all the questions by clicking on the **Question Paper** button. This feature is provided, so that if you want you can just see the entire question paper at a glance.

Answering a Question :

8. Procedure for answering a multiple choice (MCQ) type question:
 - a. Choose one answer from the 4 options (A,B,C,D) given below the question, click on the bubble placed before the chosen option.
 - b. To deselect your chosen answer, click on the bubble of the chosen option again or click on the **Clear Response** button.
 - c. To change your chosen answer, click on the bubble of another option.
 - d. To save your answer, you **MUST** click on the **Save & Next** button.
9. Procedure for answering a numerical answer type question:
 - a. To enter a number as your answer, use the virtual numerical keypad.
 - b. A fraction (e.g. -0.3 or -.3) can be entered as an answer with or without '0' before the decimal point. As many as four decimal points, e.g. 12.5435 or 0.003 or -932.6711 or 12.82 can be entered.
 - c. To clear your answer, click on the **Clear Response** button.
 - d. To save your answer, you **MUST** click on the **Save & Next** button
10. To mark a question for review, click on the **Mark for Review & Next** button. *If an answer is selected (for MCQ) or entered (for numerical answer type) for a question that is **Marked for Review**, that answer will be considered in the evaluation unless the status is modified by the candidate.*
11. To change your answer to a question that has already been answered, first select that question for answering and then follow the procedure for answering that type of question.
12. Note that **ONLY** Questions for which answers are *saved* or *marked for review after answering* will be considered for evaluation.

Choosing a Section :

13. Sections in this question paper are displayed on the top bar of the screen. Questions in a Section can be viewed by clicking on the name of that Section. The Section you are currently viewing will be highlighted.
14. A checkbox is displayed for every optional Section, if any, in the Question Paper. To select the optional Section for answering, click on the checkbox for that Section.
15. If the checkbox for an optional Section is not selected, the **Save & Next** button and the **Mark for Review & Next** button will **NOT** be enabled for that Section. You will

only be able to see questions in this Section, but you will not be able to answer questions in the Section.

16. After clicking the **Save & Next** button for the last question in a Section, you will automatically be taken to the first question of the next Section in sequence.
17. You can move the mouse cursor over the name of a Section to view the answering status for that Section.

Changing the Optional Section :

18. After answering the chosen optional Section, partially or completely, you can change the optional Section by selecting the checkbox for a new Section that you want to attempt. A warning message will appear along with a table showing the number of questions answered in each of the previously chosen optional Sections and a checkbox against each of these Sections. Click on a checkbox against a Section that you want to reset and then click on the **RESET** button. Note that RESETTING a Section will DELETE all the answers for questions in that Section. Hence, if you think that you may want to select this Section again later, you will have to note down your answers for questions in that Section. If you do not want to reset the Section and want to continue answering the previously chosen optional Section, then click on the **BACK** button.
19. If you deselect the checkbox for an optional Section in the top bar, the following warning message will appear: "Deselecting the checkbox will DELETE all the answers for questions in this Section. Do you want to deselect this Section?" If you want to deselect, click on the **RESET** button. If you do not want to deselect, click on the **BACK** button.
20. You can shuffle between different Sections or change the optional Sections any number of times.

GATE 2014 Examination

ME: Mechanical Engineering

Duration: 180 minutes

Maximum Marks: 100

Read the following instructions carefully.

1. To login, enter your Registration Number and password provided to you. Kindly go through the various symbols used in the test and understand their meaning before you start the examination.
2. Once you login and after the start of the examination, you can view all the questions in the question paper, by clicking on the **View All Questions** button in the screen.
3. This question paper consists of **2 sections**, General Aptitude (GA) for **15 marks** and the subject specific GATE paper for **85 marks**. Both these sections are compulsory.
The GA section consists of **10** questions. Question numbers 1 to 5 are of 1-mark each, while question numbers 6 to 10 are of 2-mark each.
The subject specific GATE paper section consists of **55** questions, out of which question numbers 1 to 25 are of 1-mark each, while question numbers 26 to 55 are of 2-mark each.
4. Depending upon the GATE paper, there may be useful common data that may be required for answering the questions. If the paper has such useful data, the same can be viewed by clicking on the **Useful Common Data** button that appears at the top, right hand side of the screen.
5. The computer allotted to you at the examination center runs specialized software that permits only one answer to be selected for multiple-choice questions using a mouse and to enter a suitable number for the numerical answer type questions using the virtual keyboard and mouse.
6. Your answers shall be updated and saved on a server periodically and also at the end of the examination. The examination will **stop automatically** at the end of **180 minutes**.
7. In each paper a candidate can answer a total of 65 questions carrying 100 marks.
8. The question paper may consist of questions of **multiple choice type (MCQ)** and **numerical answer type**.
9. Multiple choice type questions will have four choices against A, B, C, D, out of which only **ONE** is the correct answer. The candidate has to choose the correct answer by clicking on the bubble (○) placed before the choice.
10. For numerical answer type questions, each question will have a numerical answer and there will not be any choices. **For these questions, the answer should be entered** by using the virtual keyboard that appears on the monitor and the mouse.
11. All questions that are not attempted will result in zero marks. However, wrong answers for multiple choice type questions (MCQ) will result in **NEGATIVE** marks. For all MCQ questions a wrong answer will result in deduction of $\frac{1}{3}$ marks for a 1-mark question and $\frac{2}{3}$ marks for a 2-mark question.
12. There is **NO NEGATIVE MARKING** for questions of **NUMERICAL ANSWER TYPE**.
13. Non-programmable type Calculator is allowed. Charts, graph sheets, and mathematical tables are **NOT** allowed in the Examination Hall. You must use the Scribble pad provided to you at the examination centre for all your rough work. The Scribble Pad has to be returned at the end of the examination.

Declaration by the candidate:

“I have read and understood all the above instructions. I have also read and understood clearly the instructions given on the admit card and shall follow the same. I also understand that in case I am found to violate any of these instructions, my candidature is liable to be cancelled. I also confirm that at the start of the examination all the computer hardware allotted to me are in proper working condition”.

Q. 1 – Q. 5 carry one mark each.

- Q.1 Choose the most appropriate phrase from the options given below to complete the following sentence.

The aircraft _____ take off as soon as its flight plan was filed.

- (A) is allowed to (B) will be allowed to
(C) was allowed to (D) has been allowed to

- Q.2 Read the statements:

All women are entrepreneurs.
Some women are doctors.

Which of the following conclusions can be logically inferred from the above statements?

- (A) All women are doctors (B) All doctors are entrepreneurs
(C) All entrepreneurs are women (D) Some entrepreneurs are doctors

- Q.3 Choose the most appropriate word from the options given below to complete the following sentence.

Many ancient cultures attributed disease to supernatural causes. However, modern science has largely helped _____ such notions.

- (A) impel (B) dispel (C) propel (D) repel

- Q.4 The statistics of runs scored in a series by four batsmen are provided in the following table. Who is the most consistent batsman of these four?

Batsman	Average	Standard deviation
K	31.2	5.21
L	46.0	6.35
M	54.4	6.22
N	17.9	5.90

- (A) K (B) L (C) M (D) N

- Q.5 What is the next number in the series?

12 35 81 173 357 _____

Q. 6 – Q. 10 carry two marks each.

- Q.6 Find the odd one from the following group:

W,E,K,O I,Q,W,A F,N,T,X N,V,B,D

- (A) W,E,K,O (B) I,Q,W,A (C) F,N,T,X (D) N,V,B,D

- Q.7 For submitting tax returns, all resident males with annual income below Rs 10 lakh should fill up Form P and all resident females with income below Rs 8 lakh should fill up Form Q. All people with incomes above Rs 10 lakh should fill up Form R, except non residents with income above Rs 15 lakhs, who should fill up Form S. All others should fill Form T. An example of a person who should fill Form T is
- (A) a resident male with annual income Rs 9 lakh
(B) a resident female with annual income Rs 9 lakh
(C) a non-resident male with annual income Rs 16 lakh
(D) a non-resident female with annual income Rs 16 lakh
- Q.8 A train that is 280 metres long, travelling at a uniform speed, crosses a platform in 60 seconds and passes a man standing on the platform in 20 seconds. What is the length of the platform in metres?
- Q.9 The exports and imports (in crores of Rs.) of a country from 2000 to 2007 are given in the following bar chart. If the trade deficit is defined as excess of imports over exports, in which year is the trade deficit $\frac{1}{5}$ th of the exports?



- (A) 2005 (B) 2004 (C) 2007 (D) 2006
- Q.10 You are given three coins: one has heads on both faces, the second has tails on both faces, and the third has a head on one face and a tail on the other. You choose a coin at random and toss it, and it comes up heads. The probability that the other face is tails is
- (A) $\frac{1}{4}$ (B) $\frac{1}{3}$ (C) $\frac{1}{2}$ (D) $\frac{2}{3}$

END OF THE QUESTION PAPER

Q. 1 – Q. 25 carry one mark each.

- Q.1 Given that the determinant of the matrix $\begin{bmatrix} 1 & 3 & 0 \\ 2 & 6 & 4 \\ -1 & 0 & 2 \end{bmatrix}$ is -12 , the determinant of the matrix $\begin{bmatrix} 2 & 6 & 0 \\ 4 & 12 & 8 \\ -2 & 0 & 4 \end{bmatrix}$ is
- (A) -96 (B) -24 (C) 24 (D) 96

- Q.2 $\lim_{x \rightarrow 0} \frac{x - \sin x}{1 - \cos x}$ is
- (A) 0 (B) 1 (C) 3 (D) not defined

- Q.3 The argument of the complex number $\frac{1+i}{1-i}$, where $i = \sqrt{-1}$, is
- (A) $-\pi$ (B) $-\frac{\pi}{2}$ (C) $\frac{\pi}{2}$ (D) π

- Q.4 The matrix form of the linear system $\frac{dx}{dt} = 3x - 5y$ and $\frac{dy}{dt} = 4x + 8y$ is
- (A) $\frac{d}{dt} \begin{Bmatrix} x \\ y \end{Bmatrix} = \begin{bmatrix} 3 & -5 \\ 4 & 8 \end{bmatrix} \begin{Bmatrix} x \\ y \end{Bmatrix}$ (B) $\frac{d}{dt} \begin{Bmatrix} x \\ y \end{Bmatrix} = \begin{bmatrix} 3 & 8 \\ 4 & -5 \end{bmatrix} \begin{Bmatrix} x \\ y \end{Bmatrix}$
- (C) $\frac{d}{dt} \begin{Bmatrix} x \\ y \end{Bmatrix} = \begin{bmatrix} 4 & -5 \\ 3 & 8 \end{bmatrix} \begin{Bmatrix} x \\ y \end{Bmatrix}$ (D) $\frac{d}{dt} \begin{Bmatrix} x \\ y \end{Bmatrix} = \begin{bmatrix} 4 & 8 \\ 3 & -5 \end{bmatrix} \begin{Bmatrix} x \\ y \end{Bmatrix}$

- Q.5 Which one of the following describes the relationship among the three vectors, $\hat{i} + \hat{j} + \hat{k}$, $2\hat{i} + 3\hat{j} + \hat{k}$ and $5\hat{i} + 6\hat{j} + 4\hat{k}$?
- (A) The vectors are mutually perpendicular (B) The vectors are linearly dependent
(C) The vectors are linearly independent (D) The vectors are unit vectors

- Q.6 A circular rod of length ' L ' and area of cross-section ' A ' has a modulus of elasticity ' E ' and coefficient of thermal expansion ' α '. One end of the rod is fixed and other end is free. If the temperature of the rod is increased by ΔT , then
- (A) stress developed in the rod is $E \alpha \Delta T$ and strain developed in the rod is $\alpha \Delta T$
(B) both stress and strain developed in the rod are zero
(C) stress developed in the rod is zero and strain developed in the rod is $\alpha \Delta T$
(D) stress developed in the rod is $E \alpha \Delta T$ and strain developed in the rod is zero

Q.7 A metallic rod of 500 mm length and 50 mm diameter, when subjected to a tensile force of 100 kN at the ends, experiences an increase in its length by 0.5 mm and a reduction in its diameter by 0.015 mm. The Poisson's ratio of the rod material is _____

Q.8 Critical damping is the

- (A) largest amount of damping for which no oscillation occurs in free vibration
- (B) smallest amount of damping for which no oscillation occurs in free vibration
- (C) largest amount of damping for which the motion is simple harmonic in free vibration
- (D) smallest amount of damping for which the motion is simple harmonic in free vibration

Q.9 A circular object of radius r rolls without slipping on a horizontal level floor with the center having velocity V . The velocity at the point of contact between the object and the floor is

- (A) zero
- (B) V in the direction of motion
- (C) V opposite to the direction of motion
- (D) V vertically upward from the floor

Q.10 For the given statements:

- I. Mating spur gear teeth is an example of higher pair
- II. A revolute joint is an example of lower pair

Indicate the correct answer.

- (A) Both I and II are false
- (B) I is true and II is false
- (C) I is false and II is true
- (D) Both I and II are true

Q.11 A rigid link PQ is 2 m long and oriented at 20° to the horizontal as shown in the figure. The magnitude and direction of velocity V_Q , and the direction of velocity V_P are given. The magnitude of V_P (in m/s) at this instant is

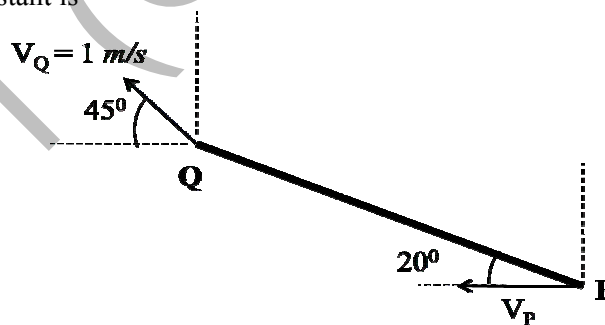

- (A) 2.14
- (B) 1.89
- (C) 1.21
- (D) 0.96

Q.12 Biot number signifies the ratio of

- (A) convective resistance in the fluid to conductive resistance in the solid
- (B) conductive resistance in the solid to convective resistance in the fluid
- (C) inertia force to viscous force in the fluid
- (D) buoyancy force to viscous force in the fluid

- Q.13 The maximum theoretical work obtainable, when a system interacts to equilibrium with a reference environment, is called
- (A) Entropy (B) Enthalpy (C) Exergy (D) Rothalpy

- Q.14 Consider a two-dimensional laminar flow over a long cylinder as shown in the figure below.

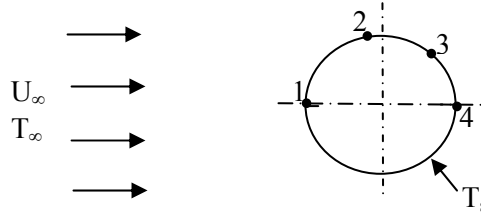

The free stream velocity is U_∞ and the free stream temperature T_∞ is lower than the cylinder surface temperature T_s . The local heat transfer coefficient is minimum at point

- (A) 1 (B) 2 (C) 3 (D) 4
- Q.15 For a completely submerged body with centre of gravity 'G' and centre of buoyancy 'B', the condition of stability will be
- (A) G is located below B (B) G is located above B
(C) G and B are coincident (D) independent of the locations of G and B
- Q.16 In a power plant, water (density = 1000 kg/m^3) is pumped from 80 kPa to 3 MPa. The pump has an isentropic efficiency of 0.85. Assuming that the temperature of the water remains the same, the specific work (in kJ/kg) supplied to the pump is
- (A) 0.34 (B) 2.48 (C) 2.92 (D) 3.43
- Q.17 Which one of the following is a CFC refrigerant?
- (A) R744 (B) R290 (C) R502 (D) R718
- Q.18 The jobs arrive at a facility, for service, in a random manner. The probability distribution of number of arrivals of jobs in a fixed time interval is
- (A) Normal (B) Poisson (C) Erlang (D) Beta
- Q.19 In exponential smoothening method, which one of the following is true?
- (A) $0 \leq \alpha \leq 1$ and high value of α is used for stable demand
(B) $0 \leq \alpha \leq 1$ and high value of α is used for unstable demand
(C) $\alpha \geq 1$ and high value of α is used for stable demand
(D) $\alpha \leq 0$ and high value of α is used for unstable demand

- Q.20 For machining a rectangular island represented by coordinates P(0,0), Q(100,0), R(100,50) and S(0,50) on a casting using CNC milling machine, an end mill with a diameter of 16 mm is used. The trajectory of the cutter centre to machine the island PQRS is
- (A) (-8, -8), (108, -8), (108,58), (-8,58), (-8, -8)
(B) (8,8), (94,8), (94,44), (8,44), (8,8)
(C) (-8,8), (94,0), (94,44), (8,44), (-8,8)
(D) (0,0), (100,0), (100,50), (50,0), (0,0)
- Q.21 Which one of the following instruments is widely used to check and calibrate geometric features of machine tools during their assembly?
- (A) Ultrasonic probe (B) Coordinate Measuring Machine (CMM)
(C) Laser interferometer (D) Vernier calipers
- Q.22 The major difficulty during welding of aluminium is due to its
- (A) high tendency of oxidation (B) high thermal conductivity
(C) low melting point (D) low density
- Q.23 The main cutting force acting on a tool during the turning (orthogonal cutting) operation of a metal is 400 N. The turning was performed using 2 mm depth of cut and 0.1 mm/rev feed rate. The specific cutting pressure (in N/mm²) is
- (A) 1000 (B) 2000 (C) 3000 (D) 4000
- Q.24 The process of reheating the martensitic steel to reduce its brittleness without any significant loss in its hardness is
- (A) normalising (B) annealing (C) quenching (D) tempering
- Q.25 In solid-state welding, the contamination layers between the surfaces to be welded are removed by
- (A) alcohol (B) plastic deformation
(C) water jet (D) sand blasting

Q. 26 – Q. 55 carry two marks each.

Q.26 The integral $\oint_C (ydx - xdy)$ is evaluated along the circle $x^2 + y^2 = \frac{1}{4}$ traversed in counter clockwise direction. The integral is equal to

- (A) 0 (B) $-\frac{\pi}{4}$ (C) $-\frac{\pi}{2}$ (D) $\frac{\pi}{4}$

Q.27 If $y = f(x)$ is the solution of $\frac{d^2y}{dx^2} = 0$ with the boundary conditions $y = 5$ at $x = 0$, and $\frac{dy}{dx} = 2$ at $x = 10$, $f(15) =$ _____

Q.28 In the following table, x is a discrete random variable and $p(x)$ is the probability density. The standard deviation of x is

x	1	2	3
$p(x)$	0.3	0.6	0.1

- (A) 0.18 (B) 0.36 (C) 0.54 (D) 0.6

Q.29 Using the trapezoidal rule, and dividing the interval of integration into three equal subintervals, the definite integral $\int_{-1}^{+1} |x| dx$ is _____

Q.30 The state of stress at a point is given by $\sigma_x = -6$ MPa, $\sigma_y = 4$ MPa, and $\tau_{xy} = -8$ MPa. The maximum tensile stress (in MPa) at the point is _____

Q.31 A block R of mass 100 kg is placed on a block S of mass 150 kg as shown in the figure. Block R is tied to the wall by a massless and inextensible string PQ. If the coefficient of static friction for all surfaces is 0.4, the minimum force **F** (in kN) needed to move the block S is

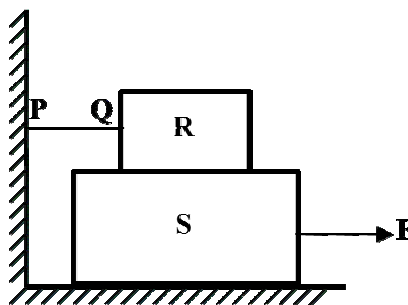

- (A) 0.69 (B) 0.88 (C) 0.98 (D) 1.37

- Q.32 A pair of spur gears with module 5 mm and a center distance of 450 mm is used for a speed reduction of 5:1. The number of teeth on pinion is _____
- Q.33 Consider a cantilever beam, having negligible mass and uniform flexural rigidity, with length 0.01 m. The frequency of vibration of the beam, with a 0.5 kg mass attached at the free tip, is 100 Hz. The flexural rigidity (in $\text{N}\cdot\text{m}^2$) of the beam is _____
- Q.34 An ideal water jet with volume flow rate of $0.05 \text{ m}^3/\text{s}$ strikes a flat plate placed normal to its path and exerts a force of 1000 N. Considering the density of water as 1000 kg/m^3 , the diameter (in mm) of the water jet is _____
- Q.35 A block weighing 200 N is in contact with a level plane whose coefficients of static and kinetic friction are 0.4 and 0.2, respectively. The block is acted upon by a horizontal force (in newton) $P=10t$, where t denotes the time in seconds. The velocity (in m/s) of the block attained after 10 seconds is _____
- Q.36 A slider crank mechanism has slider mass of 10 kg, stroke of 0.2 m and rotates with a uniform angular velocity of 10 rad/s. The primary inertia forces of the slider are partially balanced by a revolving mass of 6 kg at the crank, placed at a distance equal to crank radius. Neglect the mass of connecting rod and crank. When the crank angle (with respect to slider axis) is 30° , the unbalanced force (in newton) normal to the slider axis is _____
- Q.37 An offset slider-crank mechanism is shown in the figure at an instant. Conventionally, the Quick Return Ratio (QRR) is considered to be greater than one. The value of QRR is _____

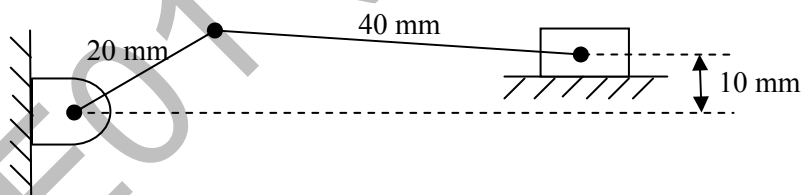

- Q.38 A rigid uniform rod AB of length L and mass m is hinged at C such that $AC = L/3$, $CB = 2L/3$. Ends A and B are supported by springs of spring constant k . The natural frequency of the system is given by

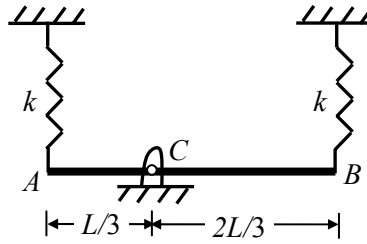

- (A) $\sqrt{\frac{k}{2m}}$ (B) $\sqrt{\frac{k}{m}}$ (C) $\sqrt{\frac{2k}{m}}$ (D) $\sqrt{\frac{5k}{m}}$
- Q.39 A hydrodynamic journal bearing is subject to 2000 N load at a rotational speed of 2000 rpm. Both bearing bore diameter and length are 40 mm. If radial clearance is 20 μm and bearing is lubricated with an oil having viscosity 0.03 Pa.s, the Sommerfeld number of the bearing is _____
- Q.40 A 200 mm long, stress free rod at room temperature is held between two immovable rigid walls. The temperature of the rod is uniformly raised by 250°C. If the Young's modulus and coefficient of thermal expansion are 200 GPa and $1 \times 10^{-5} / ^\circ\text{C}$, respectively, the magnitude of the longitudinal stress (in MPa) developed in the rod is _____
- Q.41 1.5 kg of water is in saturated liquid state at 2 bar ($v_f = 0.001061 \text{ m}^3/\text{kg}$, $u_f = 504.0 \text{ kJ/kg}$, $h_f = 505 \text{ kJ/kg}$). Heat is added in a constant pressure process till the temperature of water reaches 400°C ($v = 1.5493 \text{ m}^3/\text{kg}$, $u = 2967.0 \text{ kJ/kg}$, $h = 3277.0 \text{ kJ/kg}$). The heat added (in kJ) in the process is _____

- Q.42 Consider one dimensional steady state heat conduction across a wall (as shown in figure below) of thickness 30 mm and thermal conductivity 15 W/m.K. At $x = 0$, a constant heat flux, $q'' = 1 \times 10^5 \text{ W/m}^2$ is applied. On the other side of the wall, heat is removed from the wall by convection with a fluid at 25°C and heat transfer coefficient of $250 \text{ W/m}^2\cdot\text{K}$. The temperature (in $^\circ\text{C}$), at $x = 0$ is _____

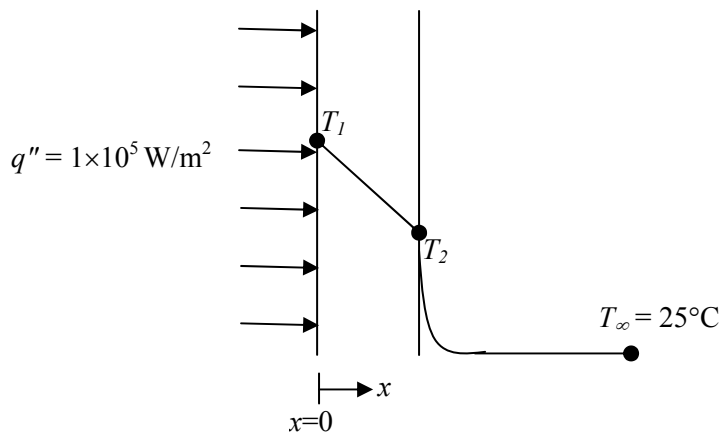

- Q.43 Water flows through a pipe having an inner radius of 10 mm at the rate of 36 kg/hr at 25°C . The viscosity of water at 25°C is $0.001 \text{ kg/m}\cdot\text{s}$. The Reynolds number of the flow is _____
- Q.44 For a fully developed flow of water in a pipe having diameter 10 cm, velocity 0.1 m/s and kinematic viscosity $10^{-5} \text{ m}^2/\text{s}$, the value of Darcy friction factor is _____
- Q.45 In a simple concentric shaft-bearing arrangement, the lubricant flows in the 2 mm gap between the shaft and the bearing. The flow may be assumed to be a plane Couette flow with zero pressure gradient. The diameter of the shaft is 100 mm and its tangential speed is 10 m/s. The dynamic viscosity of the lubricant is $0.1 \text{ kg/m}\cdot\text{s}$. The frictional resisting force (in newton) per 100 mm length of the bearing is _____
- Q.46 The non-dimensional fluid temperature profile near the surface of a convectively cooled flat plate is given by $\frac{T_w - T}{T_w - T_\infty} = a + b \frac{y}{L} + c \left(\frac{y}{L}\right)^2$, where y is measured perpendicular to the plate, L is the plate length, and a , b and c are arbitrary constants. T_w and T_∞ are wall and ambient temperatures, respectively. If the thermal conductivity of the fluid is k and the wall heat flux is q'' , the Nusselt number $Nu = \frac{q''}{T_w - T_\infty} \frac{L}{k}$ is equal to
- (A) a (B) b (C) $2c$ (D) $(b+2c)$

- Q.47 In an air-standard Otto cycle, air is supplied at 0.1 MPa and 308 K. The ratio of the specific heats (γ) and the specific gas constant (R) of air are 1.4 and 288.8 J/kg.K, respectively. If the compression ratio is 8 and the maximum temperature in the cycle is 2660 K, the heat (in kJ/kg) supplied to the engine is _____
- Q.48 A reversible heat engine receives 2 kJ of heat from a reservoir at 1000 K and a certain amount of heat from a reservoir at 800 K. It rejects 1 kJ of heat to a reservoir at 400 K. The net work output (in kJ) of the cycle is
- (A) 0.8 (B) 1.0 (C) 1.4 (D) 2.0
- Q.49 An ideal reheat Rankine cycle operates between the pressure limits of 10 kPa and 8 MPa, with reheat being done at 4 MPa. The temperature of steam at the inlets of both turbines is 500°C and the enthalpy of steam is 3185 kJ/kg at the exit of the high pressure turbine and 2247 kJ/kg at the exit of low pressure turbine. The enthalpy of water at the exit from the pump is 191 kJ/kg. Use the following table for relevant data.

Superheated steam temperature (°C)	Pressure (MPa)	v (m ³ /kg)	h (kJ/kg)	s (kJ/kg.K)
500	4	0.08644	3446	7.0922
500	8	0.04177	3399	6.7266

Disregarding the pump work, the cycle efficiency (in percentage) is _____

- Q.50 Jobs arrive at a facility at an average rate of 5 in an 8 hour shift. The arrival of the jobs follows Poisson distribution. The average service time of a job on the facility is 40 minutes. The service time follows exponential distribution. Idle time (in hours) at the facility per shift will be
- (A) $\frac{5}{7}$ (B) $\frac{14}{3}$ (C) $\frac{7}{5}$ (D) $\frac{10}{3}$
- Q.51 A metal rod of initial length L_0 is subjected to a drawing process. The length of the rod at any instant is given by the expression, $L(t) = L_0(1 + t^2)$, where t is the time in minutes. The true strain rate (in min⁻¹) at the end of one minute is _____
- Q.52 During pure orthogonal turning operation of a hollow cylindrical pipe, it is found that the thickness of the chip produced is 0.5 mm. The feed given to the zero degree rake angle tool is 0.2 mm/rev. The shear strain produced during the operation is _____

Q.53 For the given assembly: 25 H7/g8, match Group A with Group B

Group A	Group B
P. H	I. Shaft Type
Q. IT8	II. Hole Type
R. IT7	III. Hole Tolerance Grade
S. g	IV. Shaft Tolerance Grade

(A) P-I, Q-III, R-IV, S-II

(B) P-I, Q-IV, R-III, S-II

(C) P-II, Q-III, R-IV, S-I

(D) P-II, Q-IV, R-III, S-I

Q.54 If the Taylor's tool life exponent n is 0.2, and the tool changing time is 1.5 min, then the tool life (in min) for maximum production rate is _____

Q.55 An aluminium alloy (density 2600 kg/m³) casting is to be produced. A cylindrical hole of 100 mm diameter and 100 mm length is made in the casting using sand core (density 1600 kg/m³). The net buoyancy force (in newton) acting on the core is _____

END OF THE QUESTION PAPER

GATE 2014

Answer Keys for ME - Mechanical Engineering

Section	Q. No.	SESSION -	
		Key / Range	Marks
GA	1	C	1
GA	2	D	1
GA	3	B	1
GA	4	A	1
GA	5	725 to 725	1
GA	6	D	2
GA	7	B	2
GA	8	560 to 560	2
GA	9	D	2
GA	10	B	2
ME	1	A	1
ME	2	A	1
ME	3	C	1
ME	4	A	1
ME	5	B	1
ME	6	C	1
ME	7	0.29 to 0.31	1
ME	8	B	1
ME	9	A	1
ME	10	D	1
ME	11	D	1
ME	12	B	1
ME	13	C	1
ME	14	B	1
ME	15	A	1
ME	16	D	1
ME	17	C	1
ME	18	B	1
ME	19	B	1
ME	20	A	1
ME	21	C	1
ME	22	A	1
ME	23	B	1

Section	Q. No.	SESSION -	
		Key / Range	Marks
ME	24	A	1
ME	25	B	1
ME	26	C	2
ME	27	34 to 36	2
ME	28	D	2
ME	29	1.10 to 1.12	2
ME	30	8.4 to 8.5	2
ME	31	D	2
ME	32	29 to 31	2
ME	33	0.064 to 0.067	2
ME	34	56 to 57	2
ME	35	4.8 to 5.0	2
ME	36	29 to 31	2
ME	37	1.2 to 1.3	2
ME	38	D	2
ME	39	0.75 to 0.85	2
ME	40	499 to 501	2
ME	41	4155 to 4160	2
ME	42	620 to 630	2
ME	43	635 to 638	2
ME	44	0.06 to 0.07	2
ME	45	15 to 16	2
ME	46	B	2
ME	47	1400 to 1420	2
ME	48	C	2
ME	49	40 to 42	2
ME	50	B	2
ME	51	0.9 to 1.1	2
ME	52	2.8 to 3.0	2
ME	53	D	2
ME	54	5.9 to 6.1	2
ME	55	7 to 8	2

SESSION - 2

GATE 2014: General Instructions during Examination

1. Total duration of the GATE examination is **180** minutes.
2. The clock will be set at the server. The countdown timer at the top right corner of screen will display the remaining time available for you to complete the examination. When the timer reaches zero, the examination will end by itself. You need not terminate the examination or submit your paper.
3. Any useful data required for your paper can be viewed by clicking on the **Useful Common Data** button that appears on the screen.
4. Use the scribble pad provided to you for any rough work. Submit the scribble pad at the end of the examination.
5. You are allowed to use a non-programmable type calculator, however, sharing of calculators is not allowed.
6. The Question Palette displayed on the right side of screen will show the status of each question using one of the following symbols:

 You have not visited the question yet.

 You have not answered the question.

 You have answered the question.

 You have NOT answered the question, but have marked the question for review.

 You have answered the question, but marked it for review.

The **Marked for Review** status for a question simply indicates that you would like to look at that question again. *If a question is answered, but marked for review, then the answer will be considered for evaluation unless the status is modified by the candidate.*

Navigating to a Question :

7. To answer a question, do the following:
 - a. Click on the question number in the Question Palette to go to that question directly.
 - b. Select an answer for a multiple choice type question by clicking on the bubble placed before the 4 choices, namely A, B, C and D. Use the virtual numeric keypad to enter a number as answer for a numerical type question.
 - c. Click on **Save & Next** to save your answer for the current question and then go to the next question.
 - d. Click on **Mark for Review & Next** to save your answer for the current question and also mark it for review, and then go to the next question.

Caution: Note that your answer for the current question will not be saved, if you navigate to another question directly by clicking on a question number without saving the answer to the previous question.

You can view all the questions by clicking on the **Question Paper** button. This feature is provided, so that if you want you can just see the entire question paper at a glance.

Answering a Question :

8. Procedure for answering a multiple choice (MCQ) type question:
 - a. Choose one answer from the 4 options (A,B,C,D) given below the question, click on the bubble placed before the chosen option.
 - b. To deselect your chosen answer, click on the bubble of the chosen option again or click on the **Clear Response** button.
 - c. To change your chosen answer, click on the bubble of another option.
 - d. To save your answer, you MUST click on the **Save & Next** button.
9. Procedure for answering a numerical answer type question:
 - a. To enter a number as your answer, use the virtual numerical keypad.
 - b. A fraction (e.g. -0.3 or -.3) can be entered as an answer with or without '0' before the decimal point. As many as four decimal points, e.g. 12.5435 or 0.003 or -932.6711 or 12.82 can be entered.
 - c. To clear your answer, click on the **Clear Response** button.
 - d. To save your answer, you MUST click on the **Save & Next** button
10. To mark a question for review, click on the **Mark for Review & Next** button. *If an answer is selected (for MCQ) or entered (for numerical answer type) for a question that is **Marked for Review**, that answer will be considered in the evaluation unless the status is modified by the candidate.*
11. To change your answer to a question that has already been answered, first select that question for answering and then follow the procedure for answering that type of question.
12. Note that ONLY Questions for which answers are *saved* or *marked for review after answering* will be considered for evaluation.

Choosing a Section :

13. Sections in this question paper are displayed on the top bar of the screen. Questions in a Section can be viewed by clicking on the name of that Section. The Section you are currently viewing will be highlighted.
14. A checkbox is displayed for every optional Section, if any, in the Question Paper. To select the optional Section for answering, click on the checkbox for that Section.
15. If the checkbox for an optional Section is not selected, the **Save & Next** button and the **Mark for Review & Next** button will NOT be enabled for that Section. You will

only be able to see questions in this Section, but you will not be able to answer questions in the Section.

16. After clicking the **Save & Next** button for the last question in a Section, you will automatically be taken to the first question of the next Section in sequence.
17. You can move the mouse cursor over the name of a Section to view the answering status for that Section.

Changing the Optional Section :

18. After answering the chosen optional Section, partially or completely, you can change the optional Section by selecting the checkbox for a new Section that you want to attempt. A warning message will appear along with a table showing the number of questions answered in each of the previously chosen optional Sections and a checkbox against each of these Sections. Click on a checkbox against a Section that you want to reset and then click on the **RESET** button. Note that RESETTING a Section will DELETE all the answers for questions in that Section. Hence, if you think that you may want to select this Section again later, you will have to note down your answers for questions in that Section. If you do not want to reset the Section and want to continue answering the previously chosen optional Section, then click on the **BACK** button.
19. If you deselect the checkbox for an optional Section in the top bar, the following warning message will appear: "Deselecting the checkbox will DELETE all the answers for questions in this Section. Do you want to deselect this Section?" If you want to deselect, click on the **RESET** button. If you do not want to deselect, click on the **BACK** button.
20. You can shuffle between different Sections or change the optional Sections any number of times.

GATE 2014 Examination

ME: Mechanical Engineering

Duration: 180 minutes

Maximum Marks: 100

Read the following instructions carefully.

1. To login, enter your Registration Number and password provided to you. Kindly go through the various symbols used in the test and understand their meaning before you start the examination.
2. Once you login and after the start of the examination, you can view all the questions in the question paper, by clicking on the **View All Questions** button in the screen.
3. This question paper consists of **2 sections**, General Aptitude (GA) for **15 marks** and the subject specific GATE paper for **85 marks**. Both these sections are compulsory.
The GA section consists of **10** questions. Question numbers 1 to 5 are of 1-mark each, while question numbers 6 to 10 are of 2-mark each.
The subject specific GATE paper section consists of **55** questions, out of which question numbers 1 to 25 are of 1-mark each, while question numbers 26 to 55 are of 2-mark each.
4. Depending upon the GATE paper, there may be useful common data that may be required for answering the questions. If the paper has such useful data, the same can be viewed by clicking on the **Useful Common Data** button that appears at the top, right hand side of the screen.
5. The computer allotted to you at the examination center runs specialized software that permits only one answer to be selected for multiple-choice questions using a mouse and to enter a suitable number for the numerical answer type questions using the virtual keyboard and mouse.
6. Your answers shall be updated and saved on a server periodically and also at the end of the examination. The examination will **stop automatically** at the end of **180 minutes**.
7. In each paper a candidate can answer a total of 65 questions carrying 100 marks.
8. The question paper may consist of questions of **multiple choice type (MCQ)** and **numerical answer type**.
9. Multiple choice type questions will have four choices against A, B, C, D, out of which only **ONE** is the correct answer. The candidate has to choose the correct answer by clicking on the bubble (○) placed before the choice.
10. For numerical answer type questions, each question will have a numerical answer and there will not be any choices. **For these questions, the answer should be entered** by using the virtual keyboard that appears on the monitor and the mouse.
11. All questions that are not attempted will result in zero marks. However, wrong answers for multiple choice type questions (MCQ) will result in **NEGATIVE** marks. For all MCQ questions a wrong answer will result in deduction of $\frac{1}{3}$ marks for a 1-mark question and $\frac{2}{3}$ marks for a 2-mark question.
12. There is **NO NEGATIVE MARKING** for questions of **NUMERICAL ANSWER TYPE**.
13. Non-programmable type Calculator is allowed. Charts, graph sheets, and mathematical tables are **NOT** allowed in the Examination Hall. You must use the Scribble pad provided to you at the examination centre for all your rough work. The Scribble Pad has to be returned at the end of the examination.

Declaration by the candidate:

“I have read and understood all the above instructions. I have also read and understood clearly the instructions given on the admit card and shall follow the same. I also understand that in case I am found to violate any of these instructions, my candidature is liable to be cancelled. I also confirm that at the start of the examination all the computer hardware allotted to me are in proper working condition”.

Q. 1 – Q. 5 carry one mark each.

- Q.1 Choose the most appropriate word from the options given below to complete the following sentence.

Communication and interpersonal skills are _____ important in their own ways.

- (A) each (B) both (C) all (D) either

- Q.2 Which of the options given below best completes the following sentence?

She will feel much better if she _____.

- (A) will get some rest (B) gets some rest
(C) will be getting some rest (D) is getting some rest

- Q.3 Choose the most appropriate pair of words from the options given below to complete the following sentence.

She could not _____ the thought of _____ the election to her bitter rival.

- (A) bear, loosing (B) bare, loosing (C) bear, losing (D) bare, losing

- Q.4 A regular die has six sides with numbers 1 to 6 marked on its sides. If a very large number of throws show the following frequencies of occurrence: 1 → 0.167; 2 → 0.167; 3 → 0.152; 4 → 0.166; 5 → 0.168; 6 → 0.180. We call this die

- (A) irregular (B) biased (C) Gaussian (D) insufficient

- Q.5 Fill in the missing number in the series.

2 3 6 15 _____ 157.5 630

Q. 6 – Q. 10 carry two marks each.

- Q.6 Find the odd one in the following group

Q,W,Z,B B,H,K,M W,C,G,J M,S,V,X

- (A) Q,W,Z,B (B) B,H,K,M (C) W,C,G,J (D) M,S,V,X

- Q.7 Lights of four colors (red, blue, green, yellow) are hung on a ladder. On every step of the ladder there are two lights. If one of the lights is red, the other light on that step will always be blue. If one of the lights on a step is green, the other light on that step will always be yellow. Which of the following statements is not necessarily correct?

- (A) The number of red lights is equal to the number of blue lights
(B) The number of green lights is equal to the number of yellow lights
(C) The sum of the red and green lights is equal to the sum of the yellow and blue lights
(D) The sum of the red and blue lights is equal to the sum of the green and yellow lights

- Q.8 The sum of eight consecutive odd numbers is 656. The average of four consecutive even numbers is 87. What is the sum of the smallest odd number and second largest even number?

- Q.9 The total exports and revenues from the exports of a country are given in the two charts shown below. The pie chart for exports shows the quantity of each item exported as a percentage of the total quantity of exports. The pie chart for the revenues shows the percentage of the total revenue generated through export of each item. The total quantity of exports of all the items is 500 thousand tonnes and the total revenues are 250 crore rupees. Which item among the following has generated the maximum revenue per kg?

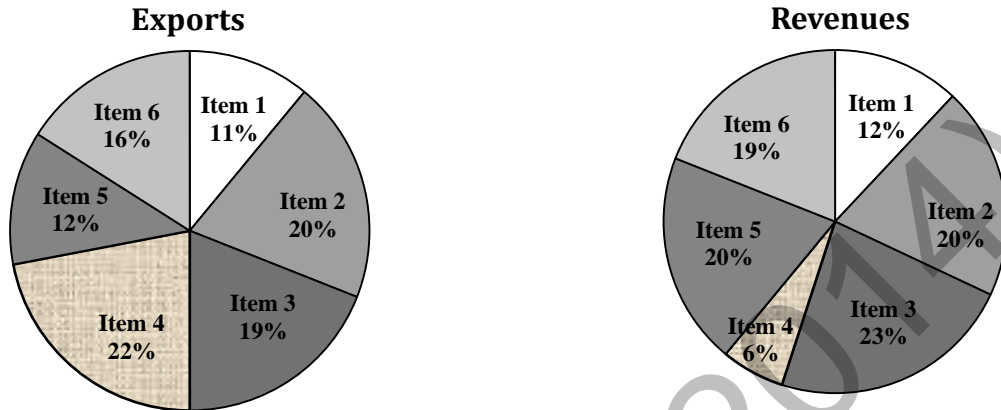

- (A) Item 2 (B) Item 3 (C) Item 6 (D) Item 5
- Q.10 It takes 30 minutes to empty a half-full tank by draining it at a constant rate. It is decided to simultaneously pump water into the half-full tank while draining it. What is the rate at which water has to be pumped in so that it gets fully filled in 10 minutes?
- (A) 4 times the draining rate (B) 3 times the draining rate
(C) 2.5 times the draining rate (D) 2 times the draining rate

END OF THE QUESTION PAPER

Q. 1 – Q. 25 carry one mark each.

Q.1 One of the eigenvectors of the matrix $\begin{bmatrix} -5 & 2 \\ -9 & 6 \end{bmatrix}$ is

- (A) $\begin{Bmatrix} -1 \\ 1 \end{Bmatrix}$ (B) $\begin{Bmatrix} -2 \\ 9 \end{Bmatrix}$ (C) $\begin{Bmatrix} 2 \\ -1 \end{Bmatrix}$ (D) $\begin{Bmatrix} 1 \\ 1 \end{Bmatrix}$

Q.2 $\lim_{x \rightarrow 0} \left(\frac{e^{2x} - 1}{\sin(4x)} \right)$ is equal to

- (A) 0 (B) 0.5 (C) 1 (D) 2

Q.3 Curl of vector $\vec{F} = x^2 z^2 \hat{i} - 2xy^2 z \hat{j} + 2y^2 z^3 \hat{k}$ is

- (A) $(4yz^3 + 2xy^2)\hat{i} + 2x^2 z \hat{j} - 2y^2 z \hat{k}$ (B) $(4yz^3 + 2xy^2)\hat{i} - 2x^2 z \hat{j} - 2y^2 z \hat{k}$
 (C) $2xz^2 \hat{i} - 4xyz \hat{j} + 6y^2 z^2 \hat{k}$ (D) $2xz^2 \hat{i} + 4xyz \hat{j} + 6y^2 z^2 \hat{k}$

Q.4 A box contains 25 parts of which 10 are defective. Two parts are being drawn simultaneously in a random manner from the box. The probability of both the parts being good is

- (A) $\frac{7}{20}$ (B) $\frac{42}{125}$ (C) $\frac{25}{29}$ (D) $\frac{5}{9}$

Q.5 The best approximation of the minimum value attained by $e^{-x} \sin(100x)$ for $x \geq 0$ is _____

Q.6 A steel cube, with all faces free to deform, has Young's modulus, E , Poisson's ratio, ν , and coefficient of thermal expansion, α . The pressure (hydrostatic stress) developed within the cube, when it is subjected to a uniform increase in temperature, ΔT , is given by

- (A) 0 (B) $\frac{\alpha(\Delta T)E}{1-2\nu}$ (C) $-\frac{\alpha(\Delta T)E}{1-2\nu}$ (D) $\frac{\alpha(\Delta T)E}{3(1-2\nu)}$

Q.7 A two member truss ABC is shown in the figure. The force (in kN) transmitted in member AB is _____

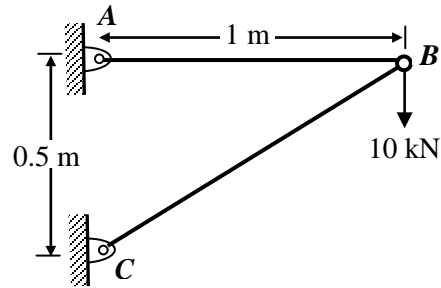

Q.8 A 4-bar mechanism with all revolute pairs has link lengths $l_f = 20$ mm, $l_{in} = 40$ mm, $l_{co} = 50$ mm and $l_{out} = 60$ mm. The suffixes ' f ', ' in ', ' co ' and ' out ' denote the fixed link, the input link, the coupler and output link respectively. Which one of the following statements is true about the input and output links?

- (A) Both links can execute full circular motion
- (B) Both links cannot execute full circular motion
- (C) Only the output link cannot execute full circular motion
- (D) Only the input link cannot execute full circular motion

Q.9 In vibration isolation, which one of the following statements is **NOT** correct regarding Transmissibility (T)?

- (A) T is nearly unity at small excitation frequencies
- (B) T can be always reduced by using higher damping at any excitation frequency
- (C) T is unity at the frequency ratio of $\sqrt{2}$
- (D) T is infinity at resonance for undamped systems

Q.10 In a structure subjected to fatigue loading, the minimum and maximum stresses developed in a cycle are 200 MPa and 400 MPa respectively. The value of stress amplitude (in MPa) is _____

Q.11 A thin plate of uniform thickness is subject to pressure as shown in the figure below

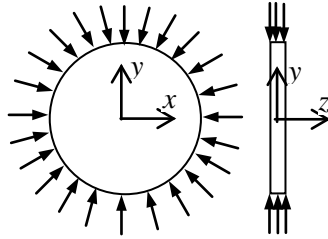

Under the assumption of plane stress, which one of the following is correct?

- (A) Normal stress is zero in the z -direction
- (B) Normal stress is tensile in the z -direction
- (C) Normal stress is compressive in the z -direction
- (D) Normal stress varies in the z -direction

Q.12 For laminar forced convection over a flat plate, if the free stream velocity increases by a factor of 2, the average heat transfer coefficient

- (A) remains same
- (B) decreases by a factor of $\sqrt{2}$
- (C) rises by a factor of $\sqrt{2}$
- (D) rises by a factor of 4

Q.13 The thermal efficiency of an air-standard Brayton cycle in terms of pressure ratio r_p and $\gamma (= c_p/c_v)$ is given by

- (A) $1 - \frac{1}{r_p^{\gamma-1}}$
- (B) $1 - \frac{1}{r_p^\gamma}$
- (C) $1 - \frac{1}{r_p^{1/\gamma}}$
- (D) $1 - \frac{1}{r_p^{(\gamma-1)/\gamma}}$

Q.14 For an incompressible flow field, \vec{V} , which one of the following conditions must be satisfied?

- (A) $\nabla \cdot \vec{V} = 0$
- (B) $\nabla \times \vec{V} = 0$
- (C) $(\vec{V} \cdot \nabla) \vec{V} = 0$
- (D) $\frac{\partial \vec{V}}{\partial t} + (\vec{V} \cdot \nabla) \vec{V} = 0$

Q.15 A pure substance at 8 MPa and 400 °C is having a specific internal energy of 2864 kJ/kg and a specific volume of 0.03432 m³/kg. Its specific enthalpy (in kJ/kg) is _____

Q.16 In a heat exchanger, it is observed that $\Delta T_1 = \Delta T_2$, where ΔT_1 is the temperature difference between the two single phase fluid streams at one end and ΔT_2 is the temperature difference at the other end. This heat exchanger is

- (A) a condenser
- (B) an evaporator
- (C) a counter flow heat exchanger
- (D) a parallel flow heat exchanger

Q.17 The difference in pressure (in N/m²) across an air bubble of diameter 0.001 m immersed in water (surface tension = 0.072 N/m) is _____

- Q.18 If there are m sources and n destinations in a transportation matrix, the total number of basic variables in a basic feasible solution is
- (A) $m + n$ (B) $m + n + 1$ (C) $m + n - 1$ (D) m

- Q.19 A component can be produced by any of the four processes I, II, III and IV. The fixed cost and the variable cost for each of the processes are listed below. The most economical process for producing a batch of 100 pieces is

Process	Fixed cost (in Rs.)	Variable cost per piece (in Rs.)
I	20	3
II	50	1
III	40	2
IV	10	4

- (A) I (B) II (C) III (D) IV

- Q.20 The flatness of a machine bed can be measured using

- (A) Vernier calipers (B) Auto collimator
(C) Height gauge (D) Tool maker's microscope

- Q.21 A robot arm PQ with end coordinates P(0,0) and Q(2,5) rotates counter clockwise about P in the XY plane by 90° . The new coordinate pair of the end point Q is

- (A) (-2,5) (B) (-5,2) (C) (-5, -2) (D) (2, -5)

- Q.22 Match the Machine Tools (Group A) with the probable Operations (Group B):

Group A	Group B
P: Centre Lathe	1: Slotting
Q: Milling	2: Counter-boring
R: Grinding	3: Knurling
S: Drilling	4: Dressing

- (A) P-1, Q-2, R-4, S-3 (B) P-2, Q-1, R-4, S-3
(C) P-3, Q-1, R-4, S-2 (D) P-3, Q-4, R-2, S-1

- Q.23 The following four unconventional machining processes are available in a shop floor. The most appropriate one to drill a hole of square cross section of $6 \text{ mm} \times 6 \text{ mm}$ and 25 mm deep is

- (A) Abrasive Jet Machining (B) Plasma Arc Machining
(C) Laser Beam Machining (D) Electro Discharge Machining

- Q.24 The relationship between true strain (ϵ_T) and engineering strain (ϵ_E) in a uniaxial tension test is given as

- (A) $\epsilon_E = \ln(1 + \epsilon_T)$ (B) $\epsilon_E = \ln(1 - \epsilon_T)$
(C) $\epsilon_T = \ln(1 + \epsilon_E)$ (D) $\epsilon_T = \ln(1 - \epsilon_E)$

Q.25 With respect to metal working, match Group A with Group B:

Group A	Group B
P: Defect in extrusion	I: alligatoring
Q: Defect in rolling	II: scab
R: Product of skew rolling	III: fish tail
S: Product of rolling through cluster mill	IV: seamless tube
	V: thin sheet with tight tolerance
	VI: semi-finished balls of ball bearing

(A) P-II, Q-III, R-VI, S-V

(B) P-III, Q-I, R-VI, S-V

(C) P-III, Q-I, R-IV, S-VI

(D) P-I, Q-II, R-V, S-VI

Q. 26 – Q. 55 carry two marks each.

Q.26 An analytic function of a complex variable $z = x + iy$ is expressed as $f(z) = u(x, y) + i v(x, y)$, where $i = \sqrt{-1}$. If $u(x, y) = 2xy$, then $v(x, y)$ must be

(A) $x^2 + y^2 + \text{constant}$

(B) $x^2 - y^2 + \text{constant}$

(C) $-x^2 + y^2 + \text{constant}$

(D) $-x^2 - y^2 + \text{constant}$

Q.27 The general solution of the differential equation $\frac{dy}{dx} = \cos(x + y)$, with c as a constant, is

(A) $y + \sin(x + y) = x + c$

(B) $\tan\left(\frac{x + y}{2}\right) = y + c$

(C) $\cos\left(\frac{x + y}{2}\right) = x + c$

(D) $\tan\left(\frac{x + y}{2}\right) = x + c$

Q.28 Consider an unbiased cubic dice with opposite faces coloured identically and each face coloured red, blue or green such that each colour appears only two times on the dice. If the dice is thrown thrice, the probability of obtaining red colour on top face of the dice at least twice is _____

Q.29 The value of $\int_{2.5}^4 \ln(x) dx$ calculated using the Trapezoidal rule with five subintervals is _____

- Q.30 The flexural rigidity (EI) of a cantilever beam is assumed to be constant over the length of the beam shown in figure. If a load P and bending moment $PL/2$ are applied at the free end of the beam then the value of the slope at the free end is

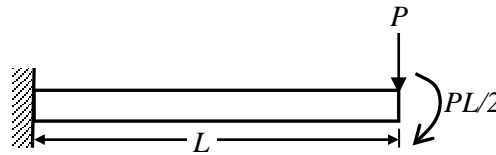

- (A) $\frac{1}{2} \frac{PL^2}{EI}$ (B) $\frac{PL^2}{EI}$ (C) $\frac{3}{2} \frac{PL^2}{EI}$ (D) $\frac{5}{2} \frac{PL^2}{EI}$
- Q.31 A cantilever beam of length, L , with uniform cross-section and flexural rigidity, EI , is loaded uniformly by a vertical load, w per unit length. The maximum vertical deflection of the beam is given by

- (A) $\frac{wL^4}{8EI}$ (B) $\frac{wL^4}{16EI}$ (C) $\frac{wL^4}{4EI}$ (D) $\frac{wL^4}{24EI}$

- Q.32 For the three bolt system shown in the figure, the bolt material has shear yield strength of 200 MPa. For a factor of safety of 2, the minimum metric specification required for the bolt is

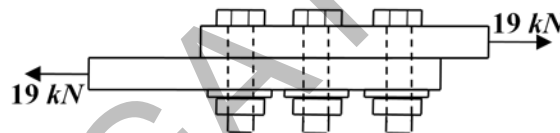

- (A) M8 (B) M10 (C) M12 (D) M16
- Q.33 Consider a flywheel whose mass M is distributed almost equally between a heavy, ring-like rim of radius R and a concentric disk-like feature of radius $R/2$. Other parts of the flywheel, such as spokes, etc, have negligible mass. The best approximation for α , if the moment of inertia of the flywheel about its axis of rotation is expressed as αMR^2 , is _____

Q.34 What is the natural frequency of the spring mass system shown below? The contact between the block and the inclined plane is frictionless. The mass of the block is denoted by m and the spring constants are denoted by k_1 and k_2 as shown below.

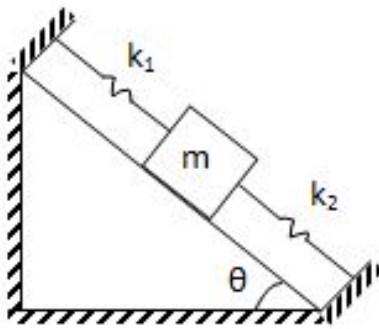

- (A) $\sqrt{\frac{k_1 + k_2}{2m}}$ (B) $\sqrt{\frac{k_1 + k_2}{4m}}$ (C) $\sqrt{\frac{k_1 - k_2}{m}}$ (D) $\sqrt{\frac{k_1 + k_2}{m}}$

Q.35 A disc clutch with a single friction surface has coefficient of friction equal to 0.3. The maximum pressure which can be imposed on the friction material is 1.5 MPa. The outer diameter of the clutch plate is 200 mm and its internal diameter is 100 mm. Assuming uniform wear theory for the clutch plate, the maximum torque (in N.m) that can be transmitted is _____

Q.36 A truck accelerates up a 10° incline with a crate of 100 kg. Value of static coefficient of friction between the crate and the truck surface is 0.3. The maximum value of acceleration (in m/s^2) of the truck such that the crate does not slide down is _____

Q.37 Maximum fluctuation of kinetic energy in an engine has been calculated to be 2600 J. Assuming that the engine runs at an average speed of 200 rpm, the polar mass moment of inertia (in $kg.m^2$) of a flywheel to keep the speed fluctuation within $\pm 0.5\%$ of the average speed is _____

Q.38 Consider the two states of stress as shown in configurations I and II in the figure below. From the standpoint of distortion energy (von-Mises) criterion, which one of the following statements is true?

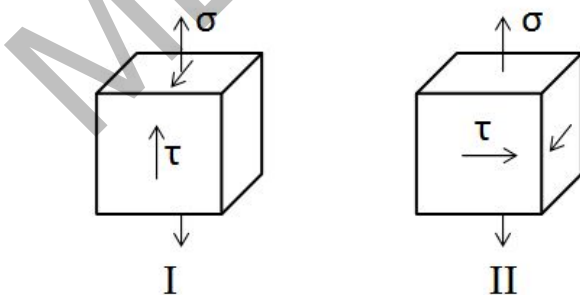

- (A) I yields after II (B) II yields after I
 (C) Both yield simultaneously (D) Nothing can be said about their relative yielding

- Q.39 A rigid link PQ of length 2 m rotates about the pinned end Q with a constant angular acceleration of 12 rad/s^2 . When the angular velocity of the link is 4 rad/s , the magnitude of the resultant acceleration (in m/s^2) of the end P is _____
- Q.40 A spur pinion of pitch diameter 50 mm rotates at 200 rad/s and transmits 3 kW power. The pressure angle of the tooth of the pinion is 20° . Assuming that only one pair of the teeth is in contact, the total force (in newton) exerted by a tooth of the pinion on the tooth on a mating gear is _____
- Q.41 A spherical balloon with a diameter of 10 m, shown in the figure below is used for advertisements. The balloon is filled with helium ($R_{He} = 2.08 \text{ kJ/kg.K}$) at ambient conditions of 15°C and 100 kPa. Assuming no disturbances due to wind, the maximum allowable weight (in newton) of balloon material and rope required to avoid the fall of the balloon ($R_{air} = 0.289 \text{ kJ/kg.K}$) is _____

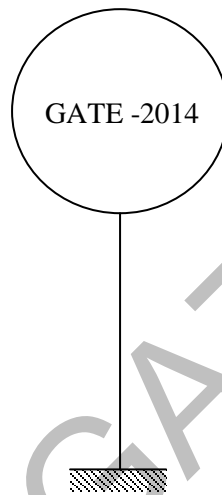

- Q.42 A hemispherical furnace of 1 m radius has the inner surface (emissivity, $\varepsilon = 1$) of its roof maintained at 800 K, while its floor ($\varepsilon = 0.5$) is kept at 600 K. Stefan-Boltzmann constant is $5.668 \times 10^{-8} \text{ W/m}^2.\text{K}^4$. The net radiative heat transfer (in kW) from the roof to the floor is _____
- Q.43 Water flows through a 10 mm diameter and 250 m long smooth pipe at an average velocity of 0.1 m/s. The density and the viscosity of water are 997 kg/m^3 and $855 \times 10^{-6} \text{ N.s/m}^2$, respectively. Assuming fully-developed flow, the pressure drop (in Pa) in the pipe is _____

- Q.44 A material P of thickness 1 mm is sandwiched between two steel slabs, as shown in the figure below. A heat flux 10 kW/m^2 is supplied to one of the steel slabs as shown. The boundary temperatures of the slabs are indicated in the figure. Assume thermal conductivity of this steel is 10 W/m.K . Considering one-dimensional steady state heat conduction for the configuration, the thermal conductivity (k , in W/m.K) of material P is _____

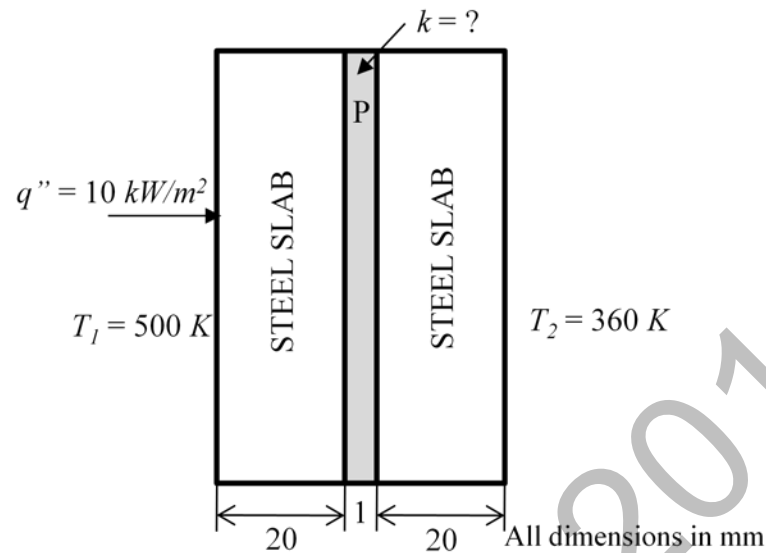

- Q.45 Consider laminar flow of water over a flat plate of length 1 m. If the boundary layer thickness at a distance of 0.25 m from the leading edge of the plate is 8 mm, the boundary layer thickness (in mm), at a distance of 0.75 m, is _____
- Q.46 In an ideal Brayton cycle, atmospheric air (ratio of specific heats, $c_p/c_v = 1.4$, specific heat at constant pressure = 1.005 kJ/kg.K) at 1 bar and 300 K is compressed to 8 bar. The maximum temperature in the cycle is limited to 1280 K. If the heat is supplied at the rate of 80 MW, the mass flow rate (in kg/s) of air required in the cycle is _____
- Q.47 Steam at a velocity of 10 m/s enters the impulse turbine stage with symmetrical blading having blade angle 30° . The enthalpy drop in the stage is 100 kJ. The nozzle angle is 20° . The maximum blade efficiency (in percent) is _____
- Q.48 In a concentric counter flow heat exchanger, water flows through the inner tube at 25°C and leaves at 42°C . The engine oil enters at 100°C and flows in the annular flow passage. The exit temperature of the engine oil is 50°C . Mass flow rate of water and the engine oil are 1.5 kg/s and 1 kg/s, respectively. The specific heat of water and oil are 4178 J/kg.K and 2130 J/kg.K , respectively. The effectiveness of this heat exchanger is _____

- Q.49 A heat pump with refrigerant R22 is used for space heating between temperature limits of -20°C and 25°C . The heat required is 200 MJ/h. Assume specific heat of vapour at the time of discharge as 0.98 kJ/kg.K. Other relevant properties are given below. The enthalpy (in kJ/kg) of the refrigerant at isentropic compressor discharge is _____

Saturation temperature	Pressure	Specific enthalpy		Specific entropy	
		$T_{\text{sat}} (^{\circ}\text{C})$	P (MN/m ²)	h_f (kJ/kg)	h_g (kJ/kg)
-20	0.2448	177.21	397.53	0.9139	1.7841
25	1.048	230.07	413.02	1.1047	1.7183

- Q.50 A project has four activities P, Q, R and S as shown below.

Activity	Normal duration (days)	Predecessor	Cost slope (Rs./day)
P	3	-	500
Q	7	P	100
R	4	P	400
S	5	R	200

The normal cost of the project is Rs. 10,000/- and the overhead cost is Rs. 200/- per day. If the project duration has to be crashed down to 9 days, the total cost (in Rupees) of the project is _____

- Q.51 Consider the following data with reference to elementary deterministic economic order quantity model

Annual demand of an item	100000
Unit price of the item (in Rs.)	10
Inventory carrying cost per unit per year (in Rs.)	1.5
Unit order cost (in Rs.)	30

The total number of economic orders per year to meet the annual demand is _____

- Q.52 For the CNC part programming, match Group A with Group B:

Group A	Group B
P: circular interpolation, counter clock wise	I: G02
Q: dwell	II: G03
R: circular interpolation, clock wise	III: G04
S: point to point counterling	IV: G00

- (A) P-II, Q-III, R-I, S-IV
(C) P-I, Q-IV, R-II, S-III

- (B) P-I, Q-III, R-II, S-IV
(D) P-II, Q-I, R-III, S-IV

- Q.53 A mild steel plate has to be rolled in one pass such that the final plate thickness is $2/3^{\text{rd}}$ of the initial thickness, with the entrance speed of 10 m/min and roll diameter of 500 mm. If the plate widens by 2% during rolling, the exit velocity (in m/min) is _____

- Q.54 A hole of 20 mm diameter is to be drilled in a steel block of 40 mm thickness. The drilling is performed at rotational speed of 400 rpm and feed rate of 0.1 mm/rev. The required approach and over run of the drill together is equal to the radius of drill. The drilling time (in minute) is
- (A) 1.00 (B) 1.25 (C) 1.50 (D) 1.75
- Q.55 A rectangular hole of size 100 mm × 50 mm is to be made on a 5 mm thick sheet of steel having ultimate tensile strength and shear strength of 500 MPa and 300 MPa, respectively. The hole is made by punching process. Neglecting the effect of clearance, the punching force (in kN) is
- (A) 300 (B) 450 (C) 600 (D) 750

END OF THE QUESTION PAPER

ME02 (GATE 2014)

GATE 2014**Answer Keys for ME - Mechanical Engineering**

Section	Q. No.	SESSION -	
		Key / Range	Marks
GA	1	B	1
GA	2	B	1
GA	3	C	1
GA	4	B	1
GA	5	45 to 45	1
GA	6	C	2
GA	7	D	2
GA	8	163 to 163	2
GA	9	D	2
GA	10	A	2
ME	1	D	1
ME	2	B	1
ME	3	A	1
ME	4	A	1
ME	5	-1.00 to -0.94	1
ME	6	A	1
ME	7	18 to 22	1
ME	8	A	1
ME	9	B	1
ME	10	99 to 101	1
ME	11	A	1
ME	12	C	1
ME	13	D	1
ME	14	A	1
ME	15	3135 to 3140	1
ME	16	C	1
ME	17	287 to 289	1
ME	18	C	1
ME	19	B	1
ME	20	B	1
ME	21	B	1
ME	22	C	1
ME	23	D	1

Section	Q. No.	SESSION -	
		Key / Range	Marks
ME	24	C	1
ME	25	B	1
ME	26	C	2
ME	27	D	2
ME	28	0.25 to 0.27	2
ME	29	1.74 to 1.76	2
ME	30	B	2
ME	31	A	2
ME	32	B	2
ME	33	0.55 to 0.57	2
ME	34	D	2
ME	35	529 to 532	2
ME	36	1.0 to 1.3	2
ME	37	590 to 595	2
ME	38	C	2
ME	39	39 to 41	2
ME	40	638 to 639	2
ME	41	5300 to 5330	2
ME	42	24.0 to 25.2	2
ME	43	6800 to 6900	2
ME	44	0.09 to 0.11	2
ME	45	13.5 to 14.2	2
ME	46	105 to 112	2
ME	47	85.1 to 89.9	2
ME	48	0.65 to 0.67	2
ME	49	430 to 440	2
ME	50	12490 to 12510	2
ME	51	49 to 51	2
ME	52	A	2
ME	53	14.6 to 14.8	2
ME	54	B	2
ME	55	B	2

SESSION - 3

GATE 2014: General Instructions during Examination

1. Total duration of the GATE examination is **180** minutes.
2. The clock will be set at the server. The countdown timer at the top right corner of screen will display the remaining time available for you to complete the examination. When the timer reaches zero, the examination will end by itself. You need not terminate the examination or submit your paper.
3. Any useful data required for your paper can be viewed by clicking on the **Useful Common Data** button that appears on the screen.
4. Use the scribble pad provided to you for any rough work. Submit the scribble pad at the end of the examination.
5. You are allowed to use a non-programmable type calculator, however, sharing of calculators is not allowed.
6. The Question Palette displayed on the right side of screen will show the status of each question using one of the following symbols:

 You have not visited the question yet.

 You have not answered the question.

 You have answered the question.

 You have NOT answered the question, but have marked the question for review.

 You have answered the question, but marked it for review.

The **Marked for Review** status for a question simply indicates that you would like to look at that question again. *If a question is answered, but marked for review, then the answer will be considered for evaluation unless the status is modified by the candidate.*

Navigating to a Question :

7. To answer a question, do the following:
 - a. Click on the question number in the Question Palette to go to that question directly.
 - b. Select an answer for a multiple choice type question by clicking on the bubble placed before the 4 choices, namely A, B, C and D. Use the virtual numeric keypad to enter a number as answer for a numerical type question.
 - c. Click on **Save & Next** to save your answer for the current question and then go to the next question.
 - d. Click on **Mark for Review & Next** to save your answer for the current question and also mark it for review, and then go to the next question.

Caution: Note that your answer for the current question will not be saved, if you navigate to another question directly by clicking on a question number without saving the answer to the previous question.

You can view all the questions by clicking on the **Question Paper** button. This feature is provided, so that if you want you can just see the entire question paper at a glance.

Answering a Question :

8. Procedure for answering a multiple choice (MCQ) type question:
 - a. Choose one answer from the 4 options (A,B,C,D) given below the question, click on the bubble placed before the chosen option.
 - b. To deselect your chosen answer, click on the bubble of the chosen option again or click on the **Clear Response** button.
 - c. To change your chosen answer, click on the bubble of another option.
 - d. To save your answer, you MUST click on the **Save & Next** button.
9. Procedure for answering a numerical answer type question:
 - a. To enter a number as your answer, use the virtual numerical keypad.
 - b. A fraction (e.g. -0.3 or -.3) can be entered as an answer with or without '0' before the decimal point. As many as four decimal points, e.g. 12.5435 or 0.003 or -932.6711 or 12.82 can be entered.
 - c. To clear your answer, click on the **Clear Response** button.
 - d. To save your answer, you MUST click on the **Save & Next** button
10. To mark a question for review, click on the **Mark for Review & Next** button. *If an answer is selected (for MCQ) or entered (for numerical answer type) for a question that is **Marked for Review**, that answer will be considered in the evaluation unless the status is modified by the candidate.*
11. To change your answer to a question that has already been answered, first select that question for answering and then follow the procedure for answering that type of question.
12. Note that ONLY Questions for which answers are *saved* or *marked for review after answering* will be considered for evaluation.

Choosing a Section :

13. Sections in this question paper are displayed on the top bar of the screen. Questions in a Section can be viewed by clicking on the name of that Section. The Section you are currently viewing will be highlighted.
14. A checkbox is displayed for every optional Section, if any, in the Question Paper. To select the optional Section for answering, click on the checkbox for that Section.
15. If the checkbox for an optional Section is not selected, the **Save & Next** button and the **Mark for Review & Next** button will NOT be enabled for that Section. You will

only be able to see questions in this Section, but you will not be able to answer questions in the Section.

16. After clicking the **Save & Next** button for the last question in a Section, you will automatically be taken to the first question of the next Section in sequence.
17. You can move the mouse cursor over the name of a Section to view the answering status for that Section.

Changing the Optional Section :

18. After answering the chosen optional Section, partially or completely, you can change the optional Section by selecting the checkbox for a new Section that you want to attempt. A warning message will appear along with a table showing the number of questions answered in each of the previously chosen optional Sections and a checkbox against each of these Sections. Click on a checkbox against a Section that you want to reset and then click on the **RESET** button. Note that RESETTING a Section will DELETE all the answers for questions in that Section. Hence, if you think that you may want to select this Section again later, you will have to note down your answers for questions in that Section. If you do not want to reset the Section and want to continue answering the previously chosen optional Section, then click on the **BACK** button.
19. If you deselect the checkbox for an optional Section in the top bar, the following warning message will appear: "Deselecting the checkbox will DELETE all the answers for questions in this Section. Do you want to deselect this Section?" If you want to deselect, click on the **RESET** button. If you do not want to deselect, click on the **BACK** button.
20. You can shuffle between different Sections or change the optional Sections any number of times.

GATE 2014 Examination

ME: Mechanical Engineering

Duration: 180 minutes

Maximum Marks: 100

Read the following instructions carefully.

1. To login, enter your Registration Number and password provided to you. Kindly go through the various symbols used in the test and understand their meaning before you start the examination.
2. Once you login and after the start of the examination, you can view all the questions in the question paper, by clicking on the **View All Questions** button in the screen.
3. This question paper consists of **2 sections**, General Aptitude (GA) for **15 marks** and the subject specific GATE paper for **85 marks**. Both these sections are compulsory.
The GA section consists of **10** questions. Question numbers 1 to 5 are of 1-mark each, while question numbers 6 to 10 are of 2-mark each.
The subject specific GATE paper section consists of **55** questions, out of which question numbers 1 to 25 are of 1-mark each, while question numbers 26 to 55 are of 2-mark each.
4. Depending upon the GATE paper, there may be useful common data that may be required for answering the questions. If the paper has such useful data, the same can be viewed by clicking on the **Useful Common Data** button that appears at the top, right hand side of the screen.
5. The computer allotted to you at the examination center runs specialized software that permits only one answer to be selected for multiple-choice questions using a mouse and to enter a suitable number for the numerical answer type questions using the virtual keyboard and mouse.
6. Your answers shall be updated and saved on a server periodically and also at the end of the examination. The examination will **stop automatically** at the end of **180 minutes**.
7. In each paper a candidate can answer a total of 65 questions carrying 100 marks.
8. The question paper may consist of questions of **multiple choice type (MCQ)** and **numerical answer type**.
9. Multiple choice type questions will have four choices against A, B, C, D, out of which only **ONE** is the correct answer. The candidate has to choose the correct answer by clicking on the bubble (○) placed before the choice.
10. For numerical answer type questions, each question will have a numerical answer and there will not be any choices. **For these questions, the answer should be entered** by using the virtual keyboard that appears on the monitor and the mouse.
11. All questions that are not attempted will result in zero marks. However, wrong answers for multiple choice type questions (MCQ) will result in **NEGATIVE** marks. For all MCQ questions a wrong answer will result in deduction of $\frac{1}{3}$ marks for a 1-mark question and $\frac{2}{3}$ marks for a 2-mark question.
12. There is **NO NEGATIVE MARKING** for questions of **NUMERICAL ANSWER TYPE**.
13. Non-programmable type Calculator is allowed. Charts, graph sheets, and mathematical tables are **NOT** allowed in the Examination Hall. You must use the Scribble pad provided to you at the examination centre for all your rough work. The Scribble Pad has to be returned at the end of the examination.

Declaration by the candidate:

“I have read and understood all the above instructions. I have also read and understood clearly the instructions given on the admit card and shall follow the same. I also understand that in case I am found to violate any of these instructions, my candidature is liable to be cancelled. I also confirm that at the start of the examination all the computer hardware allotted to me are in proper working condition”.

Q. 1 – Q. 5 carry one mark each.

Q.1 “India is a country of rich heritage and cultural diversity.”

Which one of the following facts best supports the claim made in the above sentence?

- (A) India is a union of 28 states and 7 union territories.
- (B) India has a population of over 1.1 billion.
- (C) India is home to 22 official languages and thousands of dialects.
- (D) The Indian cricket team draws players from over ten states.

Q.2 The value of one U.S. dollar is 65 Indian Rupees today, compared to 60 last year. The Indian Rupee has _____.

- (A) depressed
- (B) depreciated
- (C) appreciated
- (D) stabilized

Q.3 'Advice' is _____.

- (A) a verb
- (B) a noun
- (C) an adjective
- (D) both a verb and a noun

Q.4 The next term in the series 81, 54, 36, 24, ... is _____

Q.5 In which of the following options will the expression $P < M$ be definitely true?

- (A) $M < R > P > S$
- (B) $M > S < P < F$
- (C) $Q < M < F = P$
- (D) $P = A < R < M$

Q. 6 – Q. 10 carry two marks each.

Q.6 Find the next term in the sequence: 7G, 11K, 13M, __

- (A) 15Q
- (B) 17Q
- (C) 15P
- (D) 17P

- Q.7 The multi-level hierarchical pie chart shows the population of animals in a reserve forest. The correct conclusions from this information are:

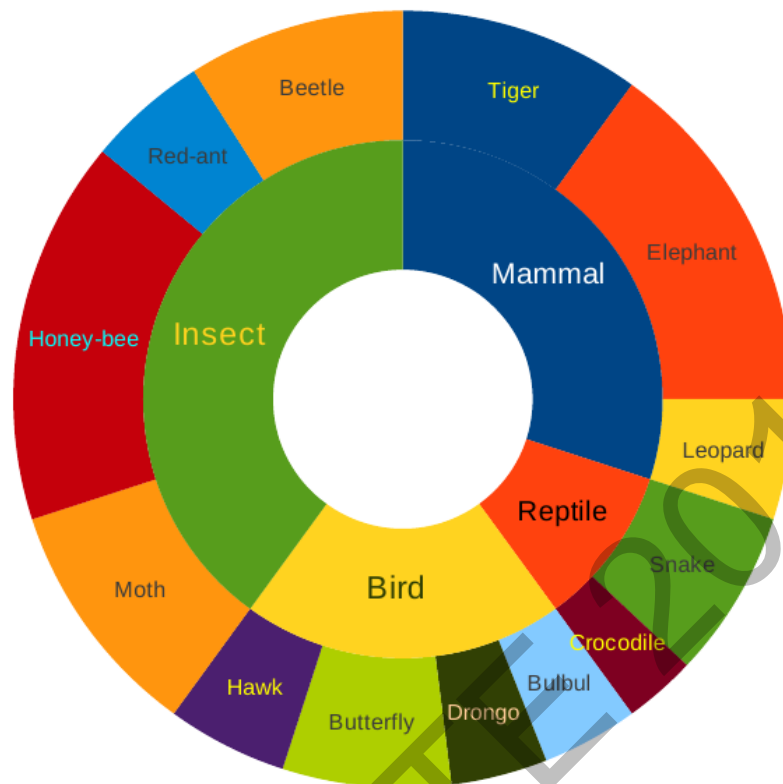

- (i) Butterflies are birds
(ii) There are more tigers in this forest than red ants
(iii) All reptiles in this forest are either snakes or crocodiles
(iv) Elephants are the largest mammals in this forest
- (A) (i) and (ii) only (B) (i), (ii), (iii) and (iv)
(C) (i), (iii) and (iv) only (D) (i), (ii) and (iii) only

- Q.8 A man can row at 8 km per hour in still water. If it takes him thrice as long to row upstream, as to row downstream, then find the stream velocity in km per hour.

- Q.9 A firm producing air purifiers sold 200 units in 2012. The following pie chart presents the share of raw material, labour, energy, plant & machinery, and transportation costs in the total manufacturing cost of the firm in 2012. The expenditure on labour in 2012 is Rs. 4,50,000. In 2013, the raw material expenses increased by 30% and all other expenses increased by 20%. If the company registered a profit of Rs. 10 lakhs in 2012, at what price (in Rs.) was each air purifier sold?

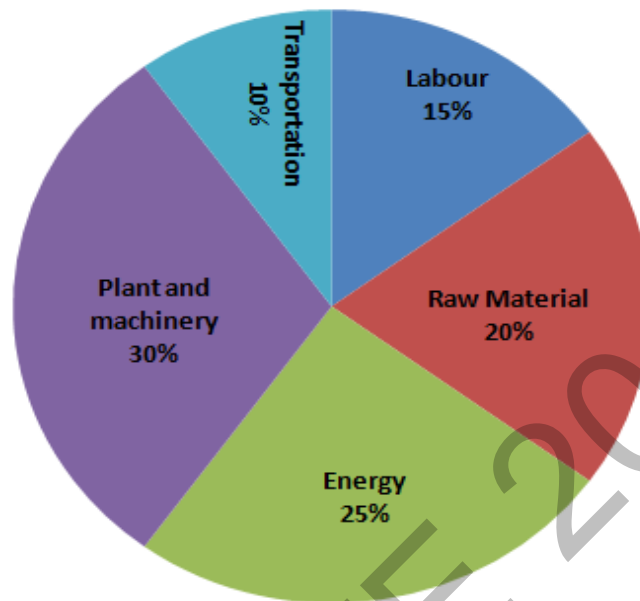

- Q.10 A batch of one hundred bulbs is inspected by testing four randomly chosen bulbs. The batch is rejected if even one of the bulbs is defective. A batch typically has five defective bulbs. The probability that the current batch is accepted is _____

END OF THE QUESTION PAPER

Q. 1 – Q. 25 carry one mark each.

- Q.1 Consider a 3×3 real symmetric matrix S such that two of its eigenvalues are $a \neq 0, b \neq 0$ with respective eigenvectors $\begin{bmatrix} x_1 \\ x_2 \\ x_3 \end{bmatrix}, \begin{bmatrix} y_1 \\ y_2 \\ y_3 \end{bmatrix}$. If $a \neq b$ then $x_1y_1 + x_2y_2 + x_3y_3$ equals
- (A) a (B) b (C) ab (D) 0
- Q.2 If a function is continuous at a point,
- (A) the limit of the function may not exist at the point
(B) the function must be derivable at the point
(C) the limit of the function at the point tends to infinity
(D) the limit must exist at the point and the value of limit should be same as the value of the function at that point
- Q.3 Divergence of the vector field $x^2z \hat{i} + xy \hat{j} - yz^2 \hat{k}$ at $(1, -1, 1)$ is
- (A) 0 (B) 3 (C) 5 (D) 6
- Q.4 A group consists of equal number of men and women. Of this group 20% of the men and 50% of the women are unemployed. If a person is selected at random from this group, the probability of the selected person being employed is _____
- Q.5 The definite integral $\int_1^3 \frac{1}{x} dx$ is evaluated using Trapezoidal rule with a step size of 1. The correct answer is _____
- Q.6 A rotating steel shaft is supported at the ends. It is subjected to a point load at the center. The maximum bending stress developed is 100 MPa. If the yield, ultimate and corrected endurance strength of the shaft material are 300 MPa, 500 MPa and 200 MPa, respectively, then the factor of safety for the shaft is _____
- Q.7 Two solid circular shafts of radii R_1 and R_2 are subjected to same torque. The maximum shear stresses developed in the two shafts are τ_1 and τ_2 . If $R_1/R_2=2$, then τ_2/τ_1 is _____
- Q.8 Consider a single degree-of-freedom system with viscous damping excited by a harmonic force. At resonance, the phase angle (in degree) of the displacement with respect to the exciting force is
- (A) 0 (B) 45 (C) 90 (D) 135

- Q.9 A mass m_1 of 100 kg travelling with a uniform velocity of 5 m/s along a line collides with a stationary mass m_2 of 1000 kg. After the collision, both the masses travel together with the same velocity. The coefficient of restitution is
- (A) 0.6 (B) 0.1 (C) 0.01 (D) 0
- Q.10 Which one of following is **NOT** correct?
- (A) Intermediate principal stress is ignored when applying the maximum principal stress theory
 (B) The maximum shear stress theory gives the most accurate results amongst all the failure theories
 (C) As per the maximum strain energy theory, failure occurs when the strain energy per unit volume exceeds a critical value
 (D) As per the maximum distortion energy theory, failure occurs when the distortion energy per unit volume exceeds a critical value
- Q.11 Gear 2 rotates at 1200 rpm in counter clockwise direction and engages with Gear 3. Gear 3 and Gear 4 are mounted on the same shaft. Gear 5 engages with Gear 4. The numbers of teeth on Gears 2, 3, 4 and 5 are 20, 40, 15 and 30, respectively. The angular speed of Gear 5 is

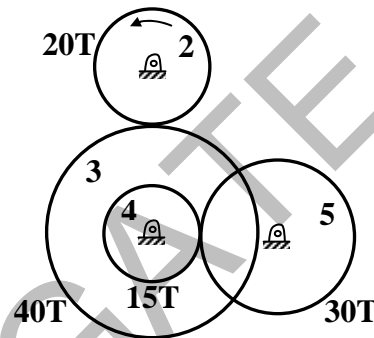

- (A) 300 rpm counterclockwise (B) 300 rpm clockwise
 (C) 4800 rpm counterclockwise (D) 4800 rpm clockwise
- Q.12 Consider a long cylindrical tube of inner and outer radii, r_i and r_o , respectively, length, L and thermal conductivity, k . Its inner and outer surfaces are maintained at T_i and T_o , respectively ($T_i > T_o$). Assuming one-dimensional steady state heat conduction in the radial direction, the thermal resistance in the wall of the tube is

- (A) $\frac{1}{2\pi k L} \ln\left(\frac{r_i}{r_o}\right)$ (B) $\frac{L}{2\pi r_i k}$
 (C) $\frac{1}{2\pi k L} \ln\left(\frac{r_o}{r_i}\right)$ (D) $\frac{1}{4\pi k L} \ln\left(\frac{r_o}{r_i}\right)$

Q.13 Which one of the following pairs of equations describes an irreversible heat engine?

- (A) $\oint \delta Q > 0$ and $\oint \frac{\delta Q}{T} < 0$ (B) $\oint \delta Q < 0$ and $\oint \frac{\delta Q}{T} < 0$
 (C) $\oint \delta Q > 0$ and $\oint \frac{\delta Q}{T} > 0$ (D) $\oint \delta Q < 0$ and $\oint \frac{\delta Q}{T} > 0$

Q.14 Consider the turbulent flow of a fluid through a circular pipe of diameter, D . Identify the correct pair of statements.

- I. The fluid is well-mixed
 II. The fluid is unmixed
 III. $Re_D < 2300$
 IV. $Re_D > 2300$

- (A) I, III (B) II, IV (C) II, III (D) I, IV

Q.15 For a gas turbine power plant, identify the correct pair of statements.

- P. Smaller in size compared to steam power plant for same power output
 Q. Starts quickly compared to steam power plant
 R. Works on the principle of Rankine cycle
 S. Good compatibility with solid fuel

- (A) P, Q (B) R, S (C) Q, R (D) P, S

Q.16 A source at a temperature of 500 K provides 1000 kJ of heat. The temperature of environment is 27°C. The maximum useful work (in kJ) that can be obtained from the heat source is _____

Q.17 A sample of moist air at a total pressure of 85 kPa has a dry bulb temperature of 30°C (saturation vapour pressure of water = 4.24 kPa). If the air sample has a relative humidity of 65%, the absolute humidity (in gram) of water vapour per kg of dry air is _____

Q.18 The process utilizing mainly thermal energy for removing material is

- (A) Ultrasonic Machining (B) Electrochemical Machining
 (C) Abrasive Jet Machining (D) Laser Beam Machining

Q.19 The actual sales of a product in different months of a particular year are given below:

September	October	November	December	January	February
180	280	250	190	240	?

The forecast of the sales, using the 4-month moving average method, for the month of February is _____

Q.20 A straight turning operation is carried out using a single point cutting tool on an AISI 1020 steel rod. The feed is 0.2 mm/rev and the depth of cut is 0.5 mm. The tool has a side cutting edge angle of 60° . The uncut chip thickness (in mm) is _____

Q.21 A minimal spanning tree in network flow models involves

- (A) all the nodes with cycle/loop allowed (B) all the nodes with cycle/loop not allowed
 (C) shortest path between start and end nodes (D) all the nodes with directed arcs

Q.22 Match the casting defects (Group A) with the probable causes (Group B):

Group A	Group B
P: Hot tears	1: Improper fusion of two streams of liquid metal
Q: Shrinkage	2: Low permeability of the sand mould
R: Blow holes	3: Volumetric contraction both in liquid and solid stage
S: Cold Shut	4: Differential cooling rate

- (A) P-1, Q-3, R-2, S-4 (B) P-4, Q-3, R-2, S-1
 (C) P-3, Q-4, R-2, S-1 (D) P-1, Q-2, R-4, S-3

Q.23 Cutting tool is much harder than the workpiece. Yet the tool wears out during the tool-work interaction, because

- (A) extra hardness is imparted to the workpiece due to coolant used
 (B) oxide layers on the workpiece surface impart extra hardness to it
 (C) extra hardness is imparted to the workpiece due to severe rate of strain
 (D) vibration is induced in the machine tool

- Q.24 The stress-strain curve for mild steel is shown in the figure given below. Choose the correct option referring to both figure and table.

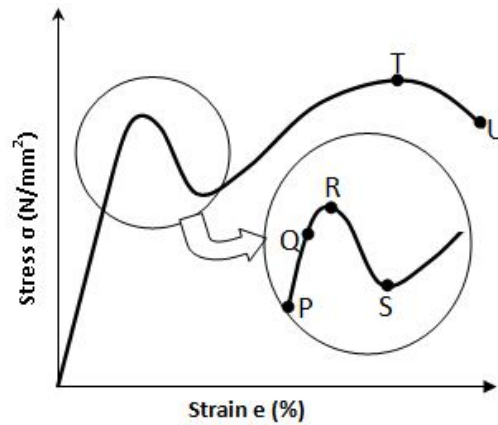

Point on the graph	Description of the point
P	1. Upper Yield Point
Q	2. Ultimate Tensile Strength
R	3. Proportionality Limit
S	4. Elastic Limit
T	5. Lower Yield Point
U	6. Failure

- (A) P-1, Q-2, R-3, S-4, T-5, U-6
 (B) P-3, Q-1, R-4, S-2, T-6, U-5
 (C) P-3, Q-4, R-1, S-5, T-2, U-6
 (D) P-4, Q-1, R-5, S-2, T-3, U-6

- Q.25 The hot tearing in a metal casting is due to

- (A) high fluidity
 (B) high melt temperature
 (C) wide range of solidification temperature
 (D) low coefficient of thermal expansion

Q. 26 – Q. 55 carry two marks each.

Q.26 An analytic function of a complex variable $z = x + iy$ is expressed as $f(z) = u(x, y) + iv(x, y)$, where $i = \sqrt{-1}$. If $u(x, y) = x^2 - y^2$, then expression for $v(x, y)$ in terms of x, y and a general constant c would be

- (A) $xy + c$ (B) $\frac{x^2 + y^2}{2} + c$ (C) $2xy + c$ (D) $\frac{(x - y)^2}{2} + c$

Q.27 Consider two solutions $x(t) = x_1(t)$ and $x(t) = x_2(t)$ of the differential equation

$$\frac{d^2x(t)}{dt^2} + x(t) = 0, t > 0, \text{ such that } x_1(0) = 1, \left. \frac{dx_1(t)}{dt} \right|_{t=0} = 0, x_2(0) = 0, \left. \frac{dx_2(t)}{dt} \right|_{t=0} = 1.$$

The Wronskian $W(t) = \begin{vmatrix} x_1(t) & x_2(t) \\ \frac{dx_1(t)}{dt} & \frac{dx_2(t)}{dt} \end{vmatrix}$ at $t = \pi/2$ is

- (A) 1 (B) -1 (C) 0 (D) $\pi/2$

Q.28 A machine produces 0, 1 or 2 defective pieces in a day with associated probability of 1/6, 2/3 and 1/6, respectively. The mean value and the variance of the number of defective pieces produced by the machine in a day, respectively, are

- (A) 1 and 1/3 (B) 1/3 and 1
(C) 1 and 4/3 (D) 1/3 and 4/3

Q.29 The real root of the equation $5x - 2\cos x - 1 = 0$ (up to two decimal accuracy) is _____

Q.30 A drum brake is shown in the figure. The drum is rotating in anticlockwise direction. The coefficient of friction between drum and shoe is 0.2. The dimensions shown in the figure are in mm. The braking torque (in N.m) for the brake shoe is _____

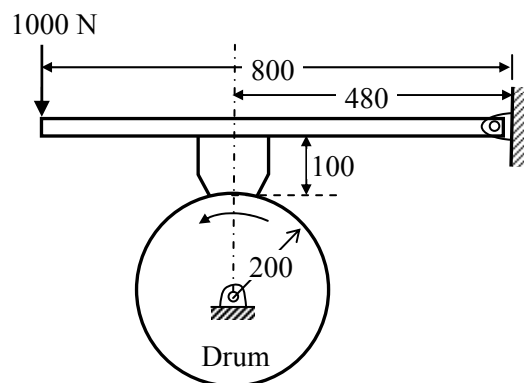

- Q.31 A body of mass (M) 10 kg is initially stationary on a 45° inclined plane as shown in figure. The coefficient of dynamic friction between the body and the plane is 0.5. The body slides down the plane and attains a velocity of 20 m/s. The distance travelled (in meter) by the body along the plane is _____

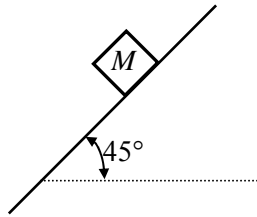

- Q.32 Consider a simply supported beam of length, $50h$, with a rectangular cross-section of depth, h , and width, $2h$. The beam carries a vertical point load, P , at its mid-point. The ratio of the maximum shear stress to the maximum bending stress in the beam is
 (A) 0.02 (B) 0.10 (C) 0.05 (D) 0.01

- Q.33 The damping ratio of a single degree of freedom spring-mass-damper system with mass of 1 kg, stiffness 100 N/m and viscous damping coefficient of 25 N.s/m is _____

- Q.34 An annular disc has a mass m , inner radius R and outer radius $2R$. The disc rolls on a flat surface without slipping. If the velocity of the center of mass is v , the kinetic energy of the disc is

- (A) $\frac{9}{16}mv^2$ (B) $\frac{11}{16}mv^2$ (C) $\frac{13}{16}mv^2$ (D) $\frac{15}{16}mv^2$

- Q.35 A force P is applied at a distance x from the end of the beam as shown in the figure. What would be the value of x so that the displacement at 'A' is equal to zero?

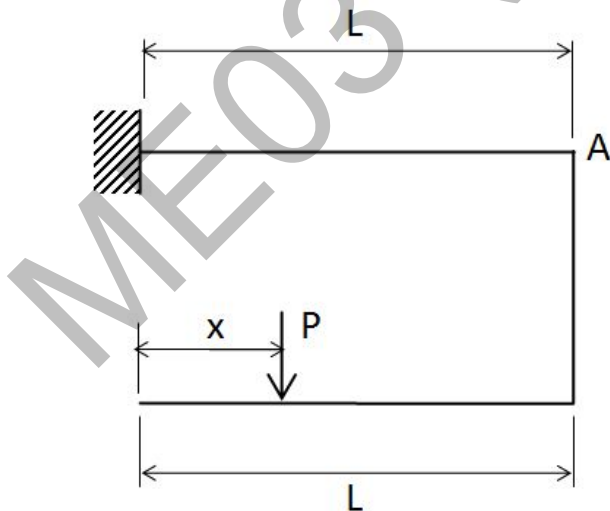

- (A) $0.5L$ (B) $0.25L$ (C) $0.33L$ (D) $0.66L$

Q.36 Consider a rotating disk cam and a translating roller follower with zero offset. Which one of the following pitch curves, parameterized by t , lying in the interval 0 to 2π , is associated with the maximum translation of the follower during one full rotation of the cam rotating about the center at $(x, y) = (0, 0)$?

(A) $x(t) = \cos t, y(t) = \sin t$

(B) $x(t) = \cos t, y(t) = 2 \sin t$

(C) $x(t) = \frac{1}{2} + \cos t, y(t) = 2 \sin t$

(D) $x(t) = \frac{1}{2} + \cos t, y(t) = \sin t$

Q.37 A four-wheel vehicle of mass 1000 kg moves uniformly in a straight line with the wheels revolving at 10 rad/s. The wheels are identical, each with a radius of 0.2 m. Then a constant braking torque is applied to all the wheels and the vehicle experiences a uniform deceleration. For the vehicle to stop in 10 s, the braking torque (in N.m) on each wheel is _____

Q.38 A slider-crank mechanism with crank radius 60 mm and connecting rod length 240 mm is shown in figure. The crank is rotating with a uniform angular speed of 10 rad/s, counter clockwise. For the given configuration, the speed (in m/s) of the slider is _____

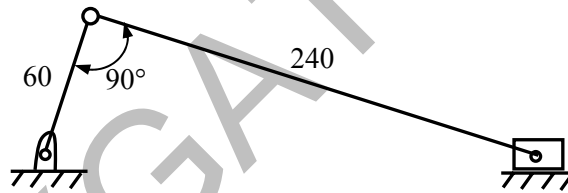

Q.39 Consider an objective function $Z(x_1, x_2) = 3x_1 + 9x_2$ and the constraints

$$\begin{aligned} x_1 + x_2 &\leq 8, \\ x_1 + 2x_2 &\leq 4, \\ x_1 &\geq 0, x_2 \geq 0. \end{aligned}$$

The maximum value of the objective function is _____

- Q.40 A mass-spring-dashpot system with mass $m = 10$ kg, spring constant $k = 6250$ N/m is excited by a harmonic excitation of $10 \cos(25t)$ N. At the steady state, the vibration amplitude of the mass is 40 mm. The damping coefficient (c , in N.s/m) of the dashpot is _____

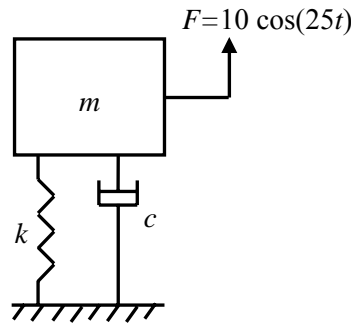

- Q.41 A certain amount of an ideal gas is initially at a pressure p_1 and temperature T_1 . First, it undergoes a constant pressure process 1-2 such that $T_2 = 3T_1/4$. Then, it undergoes a constant volume process 2-3 such that $T_3 = T_1/2$. The ratio of the final volume to the initial volume of the ideal gas is
 (A) 0.25 (B) 0.75 (C) 1.0 (D) 1.5
- Q.42 An amount of 100 kW of heat is transferred through a wall in steady state. One side of the wall is maintained at 127°C and the other side at 27°C . The entropy generated (in W/K) due to the heat transfer through the wall is _____
- Q.43 A siphon is used to drain water from a large tank as shown in the figure below. Assume that the level of water is maintained constant. Ignore frictional effect due to viscosity and losses at entry and exit. At the exit of the siphon, the velocity of water is

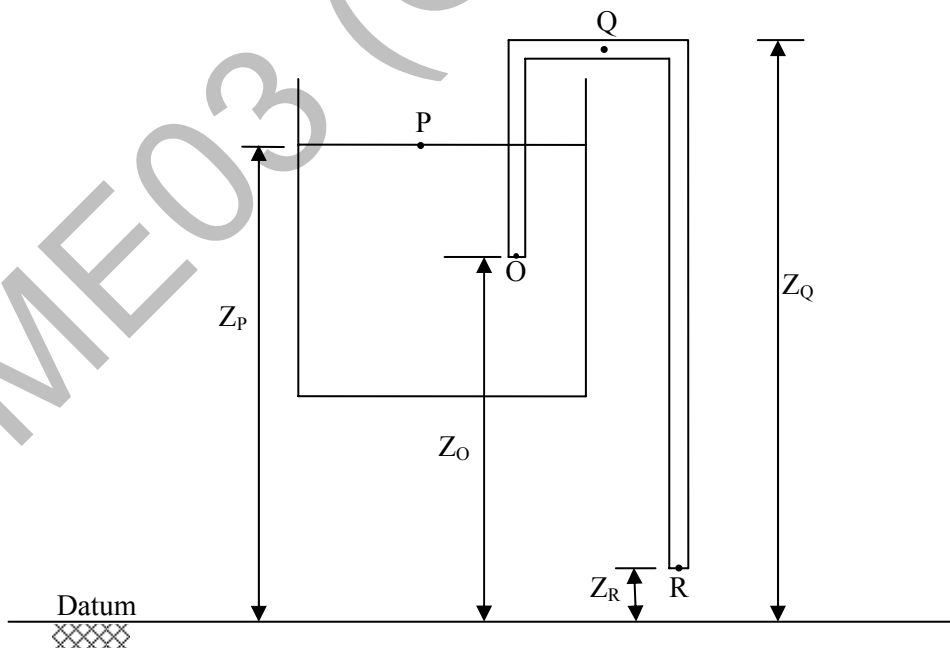

- (A) $\sqrt{2g(Z_Q - Z_R)}$ (B) $\sqrt{2g(Z_P - Z_R)}$ (C) $\sqrt{2g(Z_O - Z_R)}$ (D) $\sqrt{2gZ_Q}$

- Q.44 Heat transfer through a composite wall is shown in figure. Both the sections of the wall have equal thickness (l). The conductivity of one section is k and that of the other is $2k$. The left face of the wall is at 600 K and the right face is at 300 K.

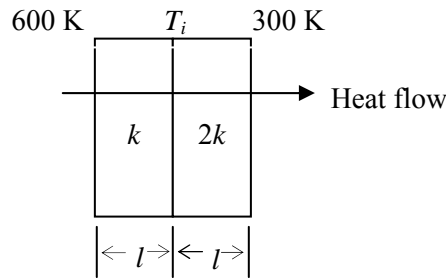

The interface temperature T_i (in K) of the composite wall is _____

- Q.45 A fluid of dynamic viscosity 2×10^{-5} kg/m.s and density 1 kg/m^3 flows with an average velocity of 1 m/s through a long duct of rectangular ($25 \text{ mm} \times 15 \text{ mm}$) cross-section. Assuming laminar flow, the pressure drop (in Pa) in the fully developed region per meter length of the duct is _____

- Q.46 At the inlet of an axial impulse turbine rotor, the blade linear speed is 25 m/s, the magnitude of absolute velocity is 100 m/s and the angle between them is 25° . The relative velocity and the axial component of velocity remain the same between the inlet and outlet of the blades. The blade inlet and outlet velocity triangles are shown in the figure. Assuming no losses, the specific work (in J/kg) is _____

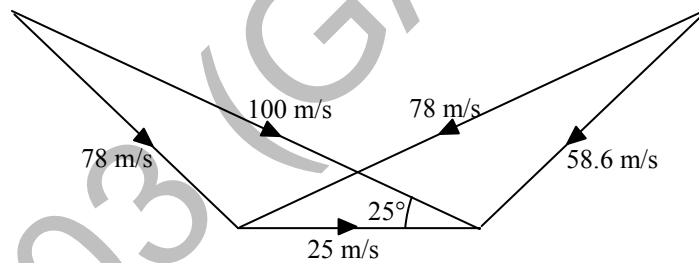

- Q.47 A solid sphere of radius $r_1 = 20 \text{ mm}$ is placed concentrically inside a hollow sphere of radius $r_2 = 30 \text{ mm}$ as shown in the figure.

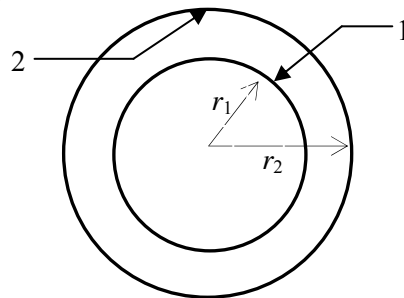

The view factor F_{21} for radiation heat transfer is

- (A) $\frac{2}{3}$ (B) $\frac{4}{9}$ (C) $\frac{8}{27}$ (D) $\frac{9}{4}$

Q.48 A double-pipe counter-flow heat exchanger transfers heat between two water streams. Tube side water at 19 liter/s is heated from 10°C to 38°C. Shell side water at 25 liter/s is entering at 46°C. Assume constant properties of water; density is 1000 kg/m³ and specific heat is 4186 J/kg.K. The LMTD (in °C) is _____

Q.49 A diesel engine has a compression ratio of 17 and cut-off takes place at 10% of the stroke. Assuming ratio of specific heats (γ) as 1.4, the air-standard efficiency (in percent) is _____

Q.50 Consider the given project network, where numbers along various activities represent the normal time. The free float on activity 4-6 and the project duration, respectively, are

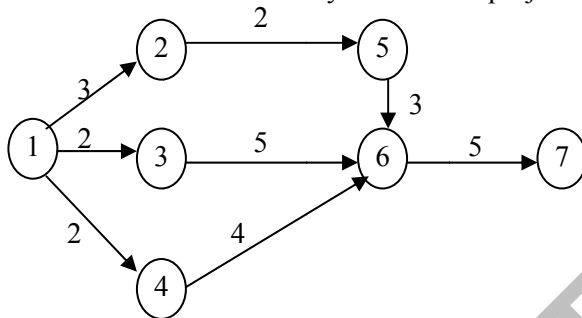

- (A) 2, 13 (B) 0, 13 (C) -2, 13 (D) 2, 12

Q.51 A manufacturer can produce 12000 bearings per day. The manufacturer received an order of 8000 bearings per day from a customer. The cost of holding a bearing in stock is Rs. 0.20 per month. Setup cost per production run is Rs. 500. Assuming 300 working days in a year, the frequency of production run should be

- (A) 4.5 days (B) 4.5 months (C) 6.8 days (D) 6.8 months

Q.52 A cylindrical blind riser with diameter d and height h , is placed on the top of the mold cavity of a closed type sand mold as shown in the figure. If the riser is of constant volume, then the rate of solidification in the riser is the least when the ratio $h:d$ is

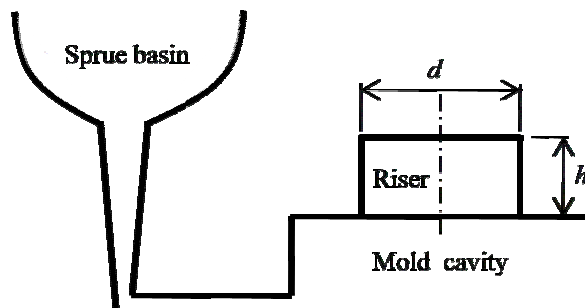

- (A) 1:2 (B) 2:1 (C) 1:4 (D) 4:1

- Q.53 The diameter of a recessed ring was measured by using two spherical balls of diameter $d_2=60$ mm and $d_1=40$ mm as shown in the figure.

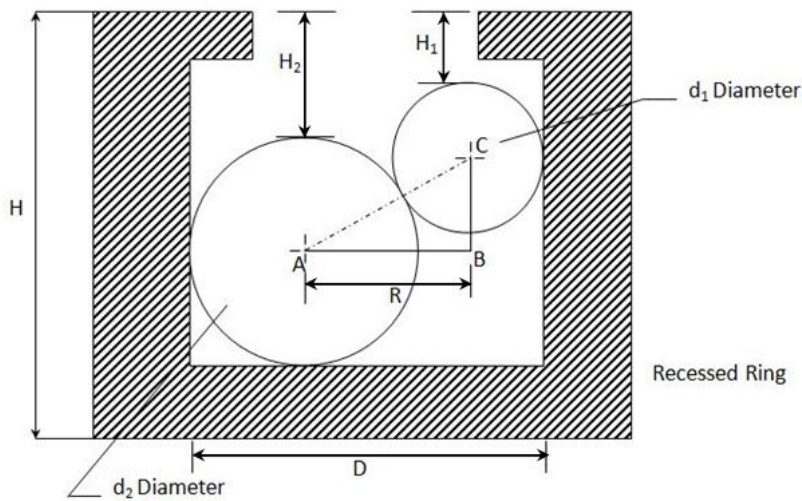

The distance $H_2=35.55$ mm and $H_1=20.55$ mm. The diameter (D , in mm) of the ring gauge is _____

- Q.54 Which pair of following statements is correct for orthogonal cutting using a single-point cutting tool?

P. Reduction in friction angle increases cutting force
 Q. Reduction in friction angle decreases cutting force
 R. Reduction in friction angle increases chip thickness
 S. Reduction in friction angle decreases chip thickness

- (A) P and R (B) P and S (C) Q and R (D) Q and S

- Q.55 For spot welding of two steel sheets (base metal) each of 3 mm thickness, welding current of 10000 A is applied for 0.2 s. The heat dissipated to the base metal is 1000 J. Assuming that the heat required for melting 1 mm^3 volume of steel is 20 J and interfacial contact resistance between sheets is 0.0002Ω , the volume (in mm^3) of weld nugget is _____

END OF THE QUESTION PAPER

GATE 2014**Answer Keys for ME - Mechanical Engineering**

Section	Q. No.	SESSION -	
		Key / Range	Marks
GA	1	C	1
GA	2	B	1
GA	3	B	1
GA	4	16 to 16	1
GA	5	D	1
GA	6	B	2
GA	7	D	2
GA	8	4 to 4	2
GA	9	20000 to 20000	2
GA	10	0.80 to 0.82	2
ME	1	D	1
ME	2	D	1
ME	3	C	1
ME	4	0.64 to 0.66	1
ME	5	1.1 to 1.2	1
ME	6	1.9 to 2.1	1
ME	7	7.9 to 8.1	1
ME	8	C	1
ME	9	D	1
ME	10	B	1
ME	11	A	1
ME	12	C	1
ME	13	A	1
ME	14	D	1
ME	15	A	1
ME	16	399 to 401	1
ME	17	19 to 22	1
ME	18	D	1
ME	19	239 to 241	1
ME	20	0.08 to 0.12	1
ME	21	B	1
ME	22	B	1
ME	23	C	1

Section	Q. No.	SESSION -	
		Key / Range	Marks
ME	24	C	1
ME	25	C	1
ME	26	C	2
ME	27	A	2
ME	28	A	2
ME	29	0.53 to 0.56	2
ME	30	63 to 65	2
ME	31	56 to 59	2
ME	32	D	2
ME	33	1.24 to 1.26	2
ME	34	C	2
ME	35	C	2
ME	36	C	2
ME	37	9 to 11	2
ME	38	0.54 to 0.68	2
ME	39	17 to 19	2
ME	40	9 to 11	2
ME	41	B	2
ME	42	80 to 85	2
ME	43	B	2
ME	44	399 to 401	2
ME	45	1.7 to 2.0	2
ME	46	3250 to 3300	2
ME	47	B	2
ME	48	10.8 to 11.2	2
ME	49	58 to 62	2
ME	50	A	2
ME	51	C	2
ME	52	A	2
ME	53	92 to 94	2
ME	54	D	2
ME	55	140 to 160	2

SESSION - 4

GATE 2014: General Instructions during Examination

1. Total duration of the GATE examination is **180** minutes.
2. The clock will be set at the server. The countdown timer at the top right corner of screen will display the remaining time available for you to complete the examination. When the timer reaches zero, the examination will end by itself. You need not terminate the examination or submit your paper.
3. Any useful data required for your paper can be viewed by clicking on the **Useful Common Data** button that appears on the screen.
4. Use the scribble pad provided to you for any rough work. Submit the scribble pad at the end of the examination.
5. You are allowed to use a non-programmable type calculator, however, sharing of calculators is not allowed.
6. The Question Palette displayed on the right side of screen will show the status of each question using one of the following symbols:

 You have not visited the question yet.

 You have not answered the question.

 You have answered the question.

 You have NOT answered the question, but have marked the question for review.

 You have answered the question, but marked it for review.

The **Marked for Review** status for a question simply indicates that you would like to look at that question again. *If a question is answered, but marked for review, then the answer will be considered for evaluation unless the status is modified by the candidate.*

Navigating to a Question :

7. To answer a question, do the following:
 - a. Click on the question number in the Question Palette to go to that question directly.
 - b. Select an answer for a multiple choice type question by clicking on the bubble placed before the 4 choices, namely A, B, C and D. Use the virtual numeric keypad to enter a number as answer for a numerical type question.
 - c. Click on **Save & Next** to save your answer for the current question and then go to the next question.
 - d. Click on **Mark for Review & Next** to save your answer for the current question and also mark it for review, and then go to the next question.

Caution: Note that your answer for the current question will not be saved, if you navigate to another question directly by clicking on a question number without saving the answer to the previous question.

You can view all the questions by clicking on the **Question Paper** button. This feature is provided, so that if you want you can just see the entire question paper at a glance.

Answering a Question :

8. Procedure for answering a multiple choice (MCQ) type question:
 - a. Choose one answer from the 4 options (A,B,C,D) given below the question, click on the bubble placed before the chosen option.
 - b. To deselect your chosen answer, click on the bubble of the chosen option again or click on the **Clear Response** button.
 - c. To change your chosen answer, click on the bubble of another option.
 - d. To save your answer, you MUST click on the **Save & Next** button.
9. Procedure for answering a numerical answer type question:
 - a. To enter a number as your answer, use the virtual numerical keypad.
 - b. A fraction (e.g. -0.3 or -.3) can be entered as an answer with or without '0' before the decimal point. As many as four decimal points, e.g. 12.5435 or 0.003 or -932.6711 or 12.82 can be entered.
 - c. To clear your answer, click on the **Clear Response** button.
 - d. To save your answer, you MUST click on the **Save & Next** button
10. To mark a question for review, click on the **Mark for Review & Next** button. *If an answer is selected (for MCQ) or entered (for numerical answer type) for a question that is **Marked for Review**, that answer will be considered in the evaluation unless the status is modified by the candidate.*
11. To change your answer to a question that has already been answered, first select that question for answering and then follow the procedure for answering that type of question.
12. Note that ONLY Questions for which answers are *saved* or *marked for review after answering* will be considered for evaluation.

Choosing a Section :

13. Sections in this question paper are displayed on the top bar of the screen. Questions in a Section can be viewed by clicking on the name of that Section. The Section you are currently viewing will be highlighted.
14. A checkbox is displayed for every optional Section, if any, in the Question Paper. To select the optional Section for answering, click on the checkbox for that Section.
15. If the checkbox for an optional Section is not selected, the **Save & Next** button and the **Mark for Review & Next** button will NOT be enabled for that Section. You will

only be able to see questions in this Section, but you will not be able to answer questions in the Section.

16. After clicking the **Save & Next** button for the last question in a Section, you will automatically be taken to the first question of the next Section in sequence.
17. You can move the mouse cursor over the name of a Section to view the answering status for that Section.

Changing the Optional Section :

18. After answering the chosen optional Section, partially or completely, you can change the optional Section by selecting the checkbox for a new Section that you want to attempt. A warning message will appear along with a table showing the number of questions answered in each of the previously chosen optional Sections and a checkbox against each of these Sections. Click on a checkbox against a Section that you want to reset and then click on the **RESET** button. Note that RESETTING a Section will DELETE all the answers for questions in that Section. Hence, if you think that you may want to select this Section again later, you will have to note down your answers for questions in that Section. If you do not want to reset the Section and want to continue answering the previously chosen optional Section, then click on the **BACK** button.
19. If you deselect the checkbox for an optional Section in the top bar, the following warning message will appear: "Deselecting the checkbox will DELETE all the answers for questions in this Section. Do you want to deselect this Section?" If you want to deselect, click on the **RESET** button. If you do not want to deselect, click on the **BACK** button.
20. You can shuffle between different Sections or change the optional Sections any number of times.

GATE 2014 Examination

ME: Mechanical Engineering

Duration: 180 minutes

Maximum Marks: 100

Read the following instructions carefully.

1. To login, enter your Registration Number and password provided to you. Kindly go through the various symbols used in the test and understand their meaning before you start the examination.
2. Once you login and after the start of the examination, you can view all the questions in the question paper, by clicking on the **View All Questions** button in the screen.
3. This question paper consists of **2 sections**, General Aptitude (GA) for **15 marks** and the subject specific GATE paper for **85 marks**. Both these sections are compulsory.
The GA section consists of **10** questions. Question numbers 1 to 5 are of 1-mark each, while question numbers 6 to 10 are of 2-mark each.
The subject specific GATE paper section consists of **55** questions, out of which question numbers 1 to 25 are of 1-mark each, while question numbers 26 to 55 are of 2-mark each.
4. Depending upon the GATE paper, there may be useful common data that may be required for answering the questions. If the paper has such useful data, the same can be viewed by clicking on the **Useful Common Data** button that appears at the top, right hand side of the screen.
5. The computer allotted to you at the examination center runs specialized software that permits only one answer to be selected for multiple-choice questions using a mouse and to enter a suitable number for the numerical answer type questions using the virtual keyboard and mouse.
6. Your answers shall be updated and saved on a server periodically and also at the end of the examination. The examination will **stop automatically** at the end of **180 minutes**.
7. In each paper a candidate can answer a total of 65 questions carrying 100 marks.
8. The question paper may consist of questions of **multiple choice type (MCQ)** and **numerical answer type**.
9. Multiple choice type questions will have four choices against A, B, C, D, out of which only **ONE** is the correct answer. The candidate has to choose the correct answer by clicking on the bubble (○) placed before the choice.
10. For numerical answer type questions, each question will have a numerical answer and there will not be any choices. **For these questions, the answer should be entered** by using the virtual keyboard that appears on the monitor and the mouse.
11. All questions that are not attempted will result in zero marks. However, wrong answers for multiple choice type questions (MCQ) will result in **NEGATIVE** marks. For all MCQ questions a wrong answer will result in deduction of $\frac{1}{3}$ marks for a 1-mark question and $\frac{2}{3}$ marks for a 2-mark question.
12. There is **NO NEGATIVE MARKING** for questions of **NUMERICAL ANSWER TYPE**.
13. Non-programmable type Calculator is allowed. Charts, graph sheets, and mathematical tables are **NOT** allowed in the Examination Hall. You must use the Scribble pad provided to you at the examination centre for all your rough work. The Scribble Pad has to be returned at the end of the examination.

Declaration by the candidate:

“I have read and understood all the above instructions. I have also read and understood clearly the instructions given on the admit card and shall follow the same. I also understand that in case I am found to violate any of these instructions, my candidature is liable to be cancelled. I also confirm that at the start of the examination all the computer hardware allotted to me are in proper working condition”.

Q. 1 – Q. 5 carry one mark each.

- Q.1 Which of the following options is the closest in meaning to the word underlined in the sentence below?

In a democracy, everybody has the freedom to disagree with the government.

- (A) dissent (B) descent (C) decent (D) decadent
- Q.2 After the discussion, Tom said to me, 'Please revert!'. He expects me to _____.
- (A) retract (B) get back to him (C) move in reverse (D) retreat
- Q.3 While receiving the award, the scientist said, "I feel vindicated". Which of the following is closest in meaning to the word 'vindicated'?
- (A) punished (B) substantiated (C) appreciated (D) chastened
- Q.4 Let $f(x, y) = x^n y^m = P$. If x is doubled and y is halved, the new value of f is
- (A) $2^{n-m}P$ (B) $2^{m-n}P$ (C) $2(n-m)P$ (D) $2(m-n)P$
- Q.5 In a sequence of 12 consecutive odd numbers, the sum of the first 5 numbers is 425. What is the sum of the last 5 numbers in the sequence?

Q. 6 – Q. 10 carry two marks each.

- Q.6 Find the next term in the sequence: 13M, 17Q, 19S, ___
- (A) 21W (B) 21V (C) 23W (D) 23V
- Q.7 If 'KCLFTSB' stands for 'best of luck' and 'SHSWDG' stands for 'good wishes', which of the following indicates 'ace the exam'?
- (A) MCHTX (B) MXHTC (C) XMHCT (D) XMHTC
- Q.8 Industrial consumption of power doubled from 2000-2001 to 2010-2011. Find the annual rate of increase in percent assuming it to be uniform over the years.
- (A) 5.6 (B) 7.2 (C) 10.0 (D) 12.2

- Q.9 A firm producing air purifiers sold 200 units in 2012. The following pie chart presents the share of raw material, labour, energy, plant & machinery, and transportation costs in the total manufacturing cost of the firm in 2012. The expenditure on labour in 2012 is Rs. 4,50,000. In 2013, the raw material expenses increased by 30% and all other expenses increased by 20%. What is the percentage increase in total cost for the company in 2013?

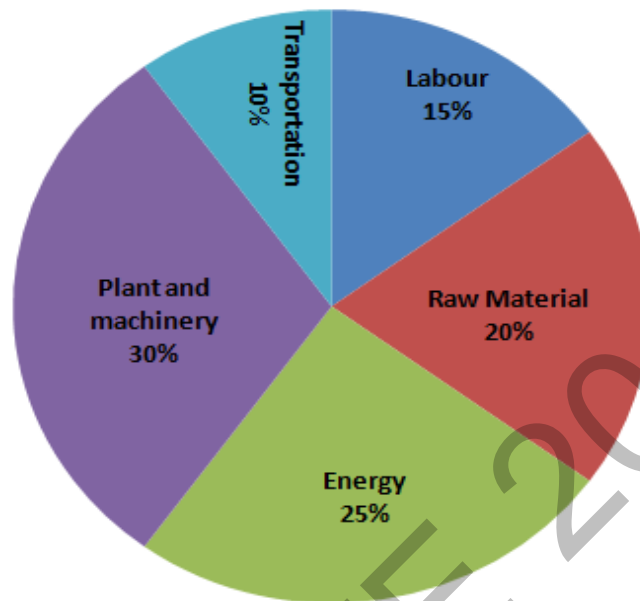

- Q.10 A five digit number is formed using the digits 1,3,5,7 and 9 without repeating any of them. What is the sum of all such possible five digit numbers?
- (A) 6666660 (B) 6666600 (C) 6666666 (D) 6666606

END OF THE QUESTION PAPER

Q. 1 – Q. 25 carry one mark each.

Q.1 Which one of the following equations is a correct identity for arbitrary 3×3 real matrices P , Q and R ?

- (A) $P(Q + R) = PQ + RP$
(B) $(P - Q)^2 = P^2 - 2PQ + Q^2$
(C) $\det(P + Q) = \det P + \det Q$
(D) $(P + Q)^2 = P^2 + PQ + QP + Q^2$

Q.2 The value of the integral $\int_0^2 \frac{(x-1)^2 \sin(x-1)}{(x-1)^2 + \cos(x-1)} dx$ is

- (A) 3 (B) 0 (C) -1 (D) -2

Q.3 The solution of the initial value problem $\frac{dy}{dx} = -2xy$; $y(0) = 2$ is

- (A) $1 + e^{-x^2}$ (B) $2e^{-x^2}$ (C) $1 + e^{x^2}$ (D) $2e^{x^2}$

Q.4 A nationalized bank has found that the daily balance available in its savings accounts follows a normal distribution with a mean of Rs. 500 and a standard deviation of Rs. 50. The percentage of savings account holders, who maintain an average daily balance more than Rs. 500 is _____

Q.5 Laplace transform of $\cos(\omega t)$ is $\frac{s}{s^2 + \omega^2}$. The Laplace transform of $e^{-2t} \cos(4t)$ is

- (A) $\frac{s-2}{(s-2)^2 + 16}$ (B) $\frac{s+2}{(s-2)^2 + 16}$
(C) $\frac{s-2}{(s+2)^2 + 16}$ (D) $\frac{s+2}{(s+2)^2 + 16}$

Q.6 In a statically determinate plane truss, the number of joints (j) and the number of members (m) are related by

- (A) $j = 2m - 3$ (B) $m = 2j + 1$ (C) $m = 2j - 3$ (D) $m = 2j - 1$

Q.7 If the Poisson's ratio of an elastic material is 0.4, the ratio of modulus of rigidity to Young's modulus is _____

Q.8 Which one of the following is used to convert a rotational motion into a translational motion?

- (A) Bevel gears (B) Double helical gears
(C) Worm gears (D) Rack and pinion gears

- Q.9 The number of independent elastic constants required to define the stress-strain relationship for an isotropic elastic solid is _____
- Q.10 A point mass is executing simple harmonic motion with an amplitude of 10 mm and frequency of 4 Hz. The maximum acceleration (m/s^2) of the mass is _____
- Q.11 Ball bearings are rated by a manufacturer for a life of 10^6 revolutions. The catalogue rating of a particular bearing is 16 kN. If the design load is 2 kN, the life of the bearing will be $p \times 10^6$ revolutions, where p is equal to _____
- Q.12 As the temperature increases, the thermal conductivity of a gas
 (A) increases (B) decreases
 (C) remains constant (D) increases up to a certain temperature and then decreases
- Q.13 A reversed Carnot cycle refrigerator maintains a temperature of -5°C . The ambient air temperature is 35°C . The heat gained by the refrigerator at a continuous rate is 2.5 kJ/s. The power (in watt) required to pump this heat out continuously is _____
- Q.14 A flow field which has only convective acceleration is
 (A) a steady uniform flow (B) an unsteady uniform flow
 (C) a steady non-uniform flow (D) an unsteady non-uniform flow
- Q.15 Match Group A with Group B:

Group A	Group B
P: Biot number	1: Ratio of buoyancy to viscous force
Q: Grashof number	2: Ratio of inertia force to viscous force
R: Prandtl number	3: Ratio of momentum to thermal diffusivities
S: Reynolds number	4: Ratio of internal thermal resistance to boundary layer thermal resistance

- (A) P-4, Q-1, R-3, S-2 (B) P-4, Q-3, R-1, S-2
 (C) P-3, Q-2, R-1, S-4 (D) P-2, Q-1, R-3, S-4
- Q.16 Kaplan water turbine is commonly used when the flow through its runner is
 (A) axial and the head available is more than 100 m
 (B) axial and the head available is less than 10 m
 (C) radial and the head available is more than 100 m
 (D) mixed and the head available is about 50 m

- Q.17 Moist air at 35°C and 100% relative humidity is entering a psychrometric device and leaving at 25°C and 100% relative humidity. The name of the device is
(A) Humidifier (B) Dehumidifier (C) Sensible heater (D) Sensible cooler
- Q.18 The total number of decision variables in the objective function of an assignment problem of size $n \times n$ (n jobs and n machines) is
(A) n^2 (B) $2n$ (C) $2n - 1$ (D) n
- Q.19 Demand during lead time with associated probabilities is shown below:

Demand	50	70	75	80	85
Probability	0.15	0.14	0.21	0.20	0.30

Expected demand during lead time is _____

- Q.20 Within the Heat Affected Zone (HAZ) in a fusion welding process, the work material undergoes
(A) microstructural changes but does not melt
(B) neither melting nor microstructural changes
(C) both melting and microstructural changes after solidification
(D) melting and retains the original microstructure after solidification
- Q.21 Two separate slab milling operations, 1 and 2, are performed with identical milling cutters. The depth of cut in operation 2 is twice that in operation 1. The other cutting parameters are identical. The ratio of maximum uncut chip thicknesses in operations 1 and 2 is _____
- Q.22 The principle of material removal in Electrochemical machining is
(A) Fick's law (B) Faraday's laws
(C) Kirchhoff's laws (D) Ohm's law
- Q.23 Better surface finish is obtained with a large rake angle because
(A) the area of shear plane decreases resulting in the decrease in shear force and cutting force
(B) the tool becomes thinner and the cutting force is reduced
(C) less heat is accumulated in the cutting zone
(D) the friction between the chip and the tool is less

- Q.24 Match the heat treatment processes (Group A) and their associated effects on properties (Group B) of medium carbon steel

Group A	Group B
P: Tempering	I: Strengthening and grain refinement
Q: Quenching	II: Inducing toughness
R: Annealing	III: Hardening
S: Normalizing	IV: Softening

- (A) P-III, Q-IV, R-II, S-I
(B) P-II, Q-III, R-IV, S-I
(C) P-III, Q-II, R-IV, S-I
(D) P-II, Q-III, R-I, S-IV

- Q.25 In a rolling process, the maximum possible draft, defined as the difference between the initial and the final thickness of the metal sheet, mainly depends on which pair of the following parameters?

P: Strain
Q: Strength of the work material
R: Roll diameter
S: Roll velocity
T: Coefficient of friction between roll and work

- (A) Q, S (B) R, T (C) S, T (D) P, R

Q. 26 – Q. 55 carry two marks each.

- Q.26 If z is a complex variable, the value of $\int_5^{3i} \frac{dz}{z}$ is

- (A) $-0.511-1.57i$ (B) $-0.511+1.57i$
(C) $0.511-1.57i$ (D) $0.511+1.57i$

- Q.27 The value of the integral $\int_0^2 \int_0^x e^{x+y} dy dx$ is

- (A) $\frac{1}{2}(e-1)$ (B) $\frac{1}{2}(e^2-1)^2$ (C) $\frac{1}{2}(e^2-e)$ (D) $\frac{1}{2}\left(e-\frac{1}{e}\right)^2$

- Q.28 The number of accidents occurring in a plant in a month follows Poisson distribution with mean as 5.2. The probability of occurrence of less than 2 accidents in the plant during a randomly selected month is

- (A) 0.029 (B) 0.034 (C) 0.039 (D) 0.044

Q.29 Consider an ordinary differential equation $\frac{dx}{dt} = 4t + 4$. If $x = x_0$ at $t = 0$, the increment in x calculated using Runge-Kutta fourth order multi-step method with a step size of $\Delta t = 0.2$ is

- (A) 0.22 (B) 0.44 (C) 0.66 (D) 0.88

Q.30 A shaft is subjected to pure torsional moment. The maximum shear stress developed in the shaft is 100 MPa. The yield and ultimate strengths of the shaft material in tension are 300 MPa and 450 MPa, respectively. The factor of safety using maximum distortion energy (von-Mises) theory is _____

Q.31 A thin gas cylinder with an internal radius of 100 mm is subject to an internal pressure of 10 MPa. The maximum permissible working stress is restricted to 100 MPa. The minimum cylinder wall thickness (in mm) for safe design must be _____

Q.32 For the truss shown in the figure, the forces F_1 and F_2 are 9 kN and 3 kN, respectively. The force (in kN) in the member QS is

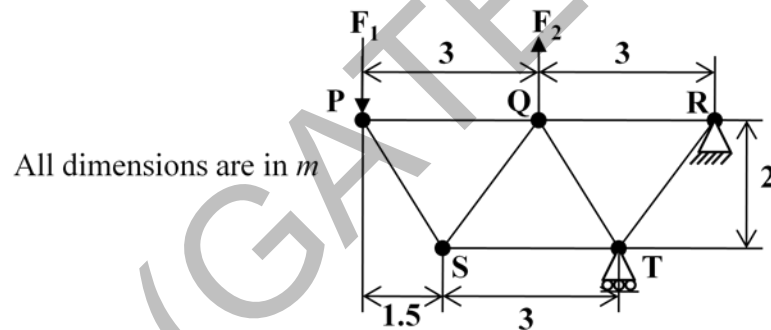

- (A) 11.25 tension (B) 11.25 compression (C) 13.5 tension (D) 13.5 compression

Q.33 It is desired to avoid interference in a pair of spur gears having a 20° pressure angle. With increase in pinion to gear speed ratio, the minimum number of teeth on the pinion

- (A) increases (B) decreases
(C) first increases and then decreases (D) remains unchanged

- Q.34 A uniform slender rod (8 m length and 3 kg mass) rotates in a vertical plane about a horizontal axis 1 m from its end as shown in the figure. The magnitude of the angular acceleration (in rad/s^2) of the rod at the position shown is _____

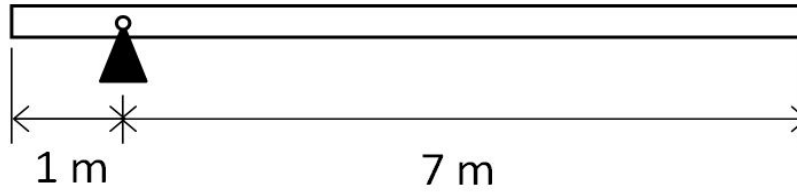

- Q.35 A bolt of major diameter 12 mm is required to clamp two steel plates. Cross sectional area of the threaded portion of the bolt is 84.3 mm^2 . The length of the threaded portion in grip is 30 mm, while the length of the unthreaded portion in grip is 8 mm. Young's modulus of material is 200 GPa. The effective stiffness (in MN/m) of the bolt in the clamped zone is _____
- Q.36 A frame is subjected to a load P as shown in the figure. The frame has a constant flexural rigidity EI . The effect of axial load is neglected. The deflection at point A due to the applied load P is

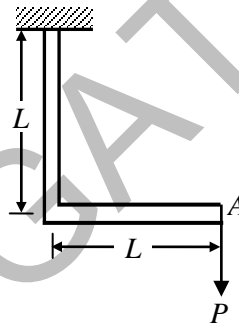

- (A) $\frac{1}{3} \frac{PL^3}{EI}$ (B) $\frac{2}{3} \frac{PL^3}{EI}$ (C) $\frac{PL^3}{EI}$ (D) $\frac{4}{3} \frac{PL^3}{EI}$

- Q.37 A wardrobe (mass 100 kg, height 4 m, width 2 m, depth 1 m), symmetric about the $Y-Y$ axis, stands on a rough level floor as shown in the figure. A force P is applied at mid-height on the wardrobe so as to tip it about point Q without slipping. What are the minimum values of the force (in newton) and the static coefficient of friction μ between the floor and the wardrobe, respectively?

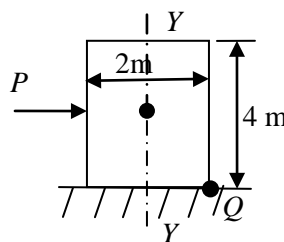

- (A) 490.5 and 0.5 (B) 981 and 0.5
(C) 1000.5 and 0.15 (D) 1000.5 and 0.25

- Q.38 Torque and angular speed data over one cycle for a shaft carrying a flywheel are shown in the figures. The moment of inertia (in $\text{kg}\cdot\text{m}^2$) of the flywheel is _____

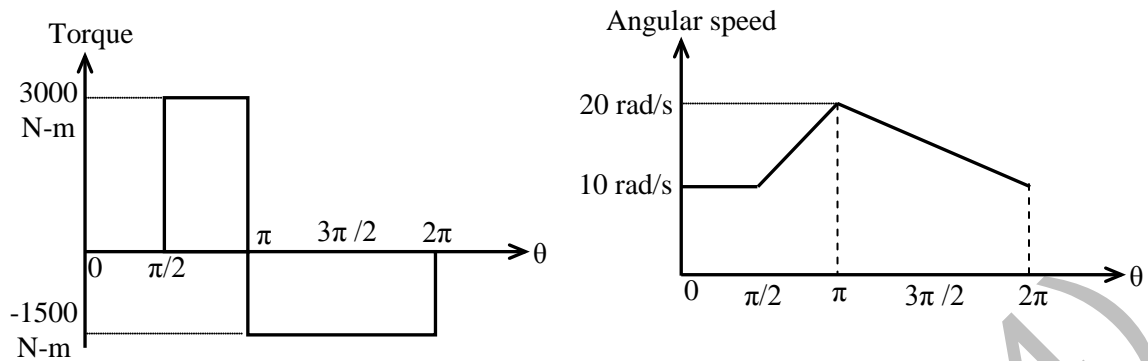

- Q.39 A single degree of freedom system has a mass of 2 kg, stiffness 8 N/m and viscous damping ratio 0.02. The dynamic magnification factor at an excitation frequency of 1.5 rad/s is _____
- Q.40 A ladder AB of length 5 m and weight (W) 600 N is resting against a wall. Assuming frictionless contact at the floor (B) and the wall (A), the magnitude of the force P (in newton) required to maintain equilibrium of the ladder is _____

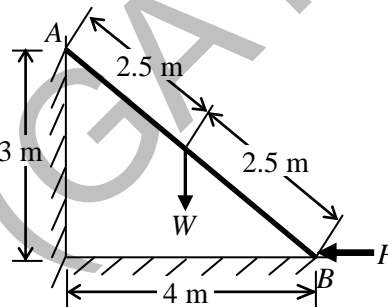

- Q.41 A closed system contains 10 kg of saturated liquid ammonia at 10°C . Heat addition required to convert the entire liquid into saturated vapour at a constant pressure is 16.2 MJ. If the entropy of the saturated liquid is $0.88 \text{ kJ/kg}\cdot\text{K}$, the entropy (in $\text{kJ/kg}\cdot\text{K}$) of saturated vapour is _____
- Q.42 A plane wall has a thermal conductivity of $1.15 \text{ W/m}\cdot\text{K}$. If the inner surface is at 1100°C and the outer surface is at 350°C , then the design thickness (in meter) of the wall to maintain a steady heat flux of 2500 W/m^2 should be _____

Q.43 Consider the following statements regarding streamline(s):

- (i) It is a continuous line such that the tangent at any point on it shows the velocity vector at that point
- (ii) There is no flow across streamlines
- (iii) $\frac{dx}{u} = \frac{dy}{v} = \frac{dz}{w}$ is the differential equation of a streamline, where u , v and w are velocities in directions x , y and z , respectively
- (iv) In an unsteady flow, the path of a particle is a streamline

Which one of the following combinations of the statements is true?

- (A) (i), (ii), (iv)
- (B) (ii), (iii), (iv)
- (C) (i), (iii), (iv)
- (D) (i), (ii), (iii)

Q.44 Consider a velocity field $\vec{V} = K(y\hat{i} + x\hat{k})$, where K is a constant. The vorticity, Ω_z , is

- (A) $-K$
- (B) K
- (C) $-K/2$
- (D) $K/2$

Q.45 Water flows through a tube of diameter 25 mm at an average velocity of 1.0 m/s. The properties of water are $\rho = 1000 \text{ kg/m}^3$, $\mu = 7.25 \times 10^{-4} \text{ N.s/m}^2$, $k = 0.625 \text{ W/m.K}$, $Pr = 4.85$. Using $Nu = 0.023 Re^{0.8} Pr^{0.4}$, the convective heat transfer coefficient (in $\text{W/m}^2.\text{K}$) is _____

Q.46 Two identical metal blocks L and M (specific heat = 0.4 kJ/kg.K), each having a mass of 5 kg, are initially at 313 K. A reversible refrigerator extracts heat from block L and rejects heat to block M until the temperature of block L reaches 293 K. The final temperature (in K) of block M is _____

Q.47 Steam with specific enthalpy (h) 3214 kJ/kg enters an adiabatic turbine operating at steady state with a flow rate 10 kg/s. As it expands, at a point where h is 2920 kJ/kg, 1.5 kg/s is extracted for heating purposes. The remaining 8.5 kg/s further expands to the turbine exit, where $h = 2374 \text{ kJ/kg}$. Neglecting changes in kinetic and potential energies, the net power output (in kW) of the turbine is _____

Q.48 Two infinite parallel plates are placed at a certain distance apart. An infinite radiation shield is inserted between the plates without touching any of them to reduce heat exchange between the plates. Assume that the emissivities of plates and radiation shield are equal. The ratio of the net heat exchange between the plates with and without the shield is

- (A) 1/2
- (B) 1/3
- (C) 1/4
- (D) 1/8

Q.49 In a compression ignition engine, the inlet air pressure is 1 bar and the pressure at the end of isentropic compression is 32.42 bar. The expansion ratio is 8. Assuming ratio of specific heats (γ) as 1.4, the air standard efficiency (in percent) is _____

- Q.50 The precedence relations and duration (in days) of activities of a project network are given in the table. The total float (in days) of activities e and f , respectively, are

Activity	Predecessors	Duration (days)
a	-	2
b	-	4
c	a	2
d	b	3
e	c	2
f	c	4
g	d, e	5

- (A) 0 and 4 (B) 1 and 4 (C) 2 and 3 (D) 3 and 1

- Q.51 At a work station, 5 jobs arrive every minute. The mean time spent on each job in the work station is $1/8$ minute. The mean steady state number of jobs in the system is _____

- Q.52 A GO-No GO plug gauge is to be designed for measuring a hole of nominal diameter 25 mm with a hole tolerance of ± 0.015 mm. Considering 10% of work tolerance to be the gauge tolerance and no wear condition, the dimension (in mm) of the GO plug gauge as per the unilateral tolerance system is

- (A) $24.985^{+0.003}_{-0.003}$ (B) $25.015^{+0.000}_{-0.006}$ (C) $24.985^{+0.03}_{-0.03}$ (D) $24.985^{+0.003}_{-0.000}$

- Q.53 A cylindrical riser of 6 cm diameter and 6 cm height has to be designed for a sand casting mould for producing a steel rectangular plate casting of $7 \text{ cm} \times 10 \text{ cm} \times 2 \text{ cm}$ dimensions having the total solidification time of 1.36 minute. The total solidification time (in minute) of the riser is _____

- Q.54 A cast iron block of 200 mm length is being shaped in a shaping machine with a depth of cut of 4 mm, feed of 0.25 mm/stroke and the tool principal cutting edge angle of 30° . Number of cutting strokes per minute is 60. Using specific energy for cutting as 1.49 J/mm^3 , the average power consumption (in watt) is _____

- Q.55 A butt weld joint is developed on steel plates having yield and ultimate tensile strength of 500 MPa and 700 MPa, respectively. The thickness of the plates is 8 mm and width is 20 mm. Improper selection of welding parameters caused an undercut of 3 mm depth along the weld. The maximum transverse tensile load (in kN) carrying capacity of the developed weld joint is _____

END OF THE QUESTION PAPER

GATE 2014**Answer Keys for ME - Mechanical Engineering**

Section	Q. No.	SESSION - 4	
		Key / Range	Marks
GA	1	A	1
GA	2	B	1
GA	3	B	1
GA	4	A	1
GA	5	495 to 495	1
GA	6	C	2
GA	7	B	2
GA	8	B	2
GA	9	22 to 22	2
GA	10	B	2
ME	1	D	1
ME	2	B	1
ME	3	B	1
ME	4	49 to 51	1
ME	5	D	1
ME	6	C	1
ME	7	0.35 to 0.36	1
ME	8	D	1
ME	9	1.9 to 2.1	1
ME	10	6.3 to 6.4	1
ME	11	500 to 540	1
ME	12	A	1
ME	13	370 to 375	1
ME	14	C	1
ME	15	A	1
ME	16	B	1
ME	17	B	1
ME	18	A	1
ME	19	74 to 75	1
ME	20	A	1
ME	21	0.70 to 0.72	1
ME	22	B	1
ME	23	A	1

Section	Q. No.	SESSION - 4	
		Key / Range	Marks
ME	24	B	1
ME	25	B	1
ME	26	B	2
ME	27	B	2
ME	28	B	2
ME	29	D	2
ME	30	1.7 to 1.8	2
ME	31	9.8 to 10.6	2
ME	32	A	2
ME	33	A	2
ME	34	1.9 to 2.1	2
ME	35	460 to 470	2
ME	36	D	2
ME	37	A	2
ME	38	30 to 32	2
ME	39	2.0 to 2.4	2
ME	40	399 to 401	2
ME	41	6.4 to 6.7	2
ME	42	0.33 to 0.35	2
ME	43	D	2
ME	44	A	2
ME	45	4600 to 4625	2
ME	46	333 to 335	2
ME	47	7580 to 7582	2
ME	48	A	2
ME	49	59 to 61	2
ME	50	B	2
ME	51	1.62 to 1.70	2
ME	52	D	2
ME	53	2.5 to 4.5	2
ME	54	295 to 305	2
ME	55	68 to 72	2